

ABOUT THE NETWORK ARCH

Per Tveit, dr. ing, Docent Emeritus, Agder University, N-4876 Grimstad, Norway, per.tveit@uia.no



Fig. 1. Bolstadstraumen Bridge has a span of 84m.

Working on his master's thesis at the technical university in Trondheim, Norway, the author came to think of an arch bridge with inclined hangers, where some of the hangers cross each other at least twice. It is called a "network arch" and it has been the centrepiece of the author's research ever since. If the tie is a concrete slab, it saves more than half the steel needed for most other steel bridges. Arch bridges with inclined hangers that cross each other no more than once should be called Nielsen bridges after [Nielsen].

The author is very grateful to IABSE for this opportunity to tell you about network arches. It means a lot to him to have this unique opportunity to present his ideas on network arches.

The first picture shows the author's second network arch. p. 7 and 8. It was finished in 1963. You can hardly see the hangers, but that is because of the way the sun is shining. You can see the electricity lines, because they reflect the sunshine.

If we define the slenderness of an arch bridge as the span divided by the sum of the height of the chords. This bridge was the world's most slender arch bridge up to 2007. Then a slimmer pedestrian bridge over the Rhine was opened. [Strobel 2007]. In 2010 an even slimmer network arch will be built in western Norway. [Larsen 2006] [Tveit 2006]. The bridge in fig. 1 needed 44 t of structural steel and 7 t of prestressing steel. The rise of the arch was 18 % of the span.

To save steel a competing arch bridge with vertical hangers had a rise of the arch of 21.5 % of the span. It needed 2.5 times more structural steel. Both bridges had a concrete slab between the arches.

This text deviates slightly from the lecture on the internet. It contains references to a list of literature. Page numbers like p. 3 refer to [Tveit 2007]. Other types of references are [Herzog 1975] or [Herzog p. 280]. The pictures might be slightly different from the slides in the lecture. The captions make a difference

Help for those who are looking for special items:

Major themes: General explanations: pp. 1-3, Comparison to bridges with vertical hangers: pp. 9-10, 13 – 15, 31 – 33, Cost 15 – 16, Erection pp. 18 – 22, 25, 31 – 33, Railway bridges pp. 22 – 25, Nielsen Bridges pp. 17 – 18, Concrete in arches pp. 15 – 16, German and Japanese network arches. pp. 16 – 17, Recent network arches pp. 26 – 30, Svinesund Bridge pp. 31 – 33, Relaxation of hangers pp. 11 – 12, Why have network arches not been built p. 26.

Minor themes: Buckling p. 11, Vibrations p. 20, Earthquake 30, Loss of hangers p. 5, Axial forces in chords of network arches p. 7, Steinkjer Bridge pp. 4 – 8, Bolstadstraumen Bridge p. 1, Blennerhassett Bridge p. 30, Fehmarn Sound Bridge p. 16, Shinhamedera Bridge p. 17, Bechyne Bridge pp. 26 – 27, Schulenburg Bridge p. 26, p. Providence Bridge p. 28, Flora Bridge p. 29.

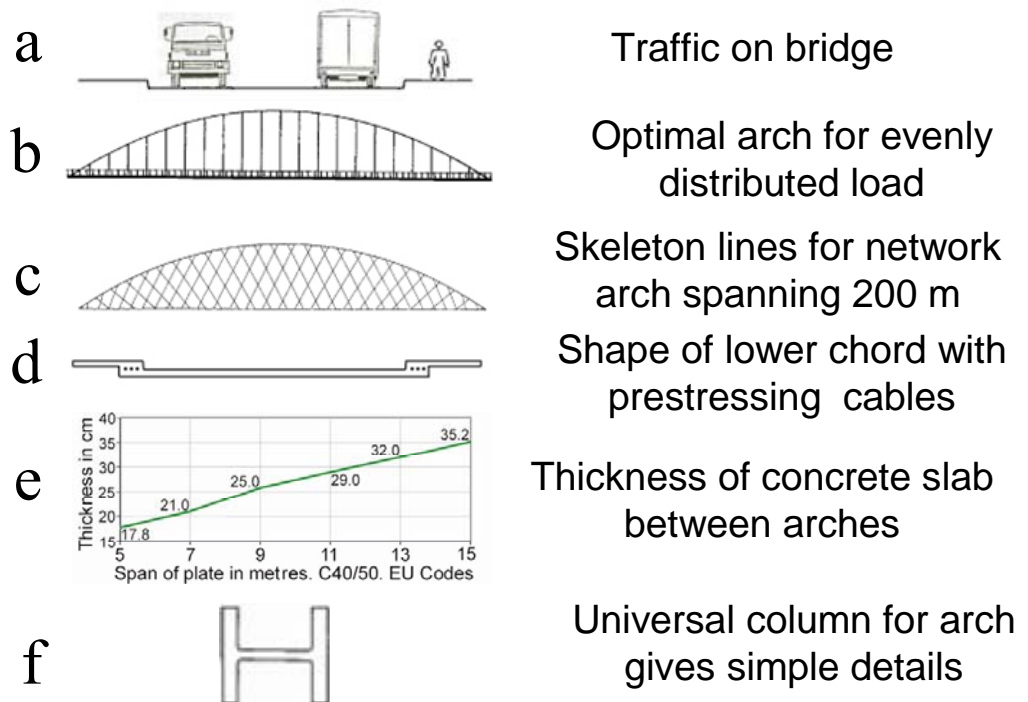

Fig. 2. Six figures that give the reasoning behind an efficient network arch.

{a} The purpose of a bridge is to take traffic over an obstacle. The traffic can be on a road as in the first sketch. Often there is no room for members under the bridge.

{b} For an evenly distributed load an arch bridge with vertical hangers is a very good solution. All the members have mainly axial forces.

{c} For uneven loads it is best to use crossing hangers as in the network arch. Then all loads are transferred to the arches in such a way that there is very little bending in the chords. The bending in the members is usually less than in trusses, that is, if we do not use the usual assumption that there is a frictionless joint in every node in the truss. As you all know, in the last hundred years the uneven loads have become a higher percentage of the loads on bridges. This speaks for the network arches.

{d} The simplest tie would be a concrete slab spanning between the arches. A slab tie spreads out concentrated loads before they reach the edge beams. Transversal beams concentrate loads.

{e} Here are the necessary thicknesses of a slab spanning between arches [Teich and Wendelin 2001]. For distances between the arches of between 10 and 18 m transversal prestress might be needed. Since there is very little longitudinal bending in the tie, it can be very slim. The tensile force in the tie is best taken by prestressing cables in the edge beams. They give a beneficial compressive stress in the tie. This leads to less maintenance of the concrete tie.

Longitudinal steel beams in the tie are not so good because they cost more. They also lead to more cracks and more maintenance of the tie. They give deeper lower chords. In network arches the added stiffness in the tie is of little value.

{f} The hangers give the arch good support in the plane of the arch. Universal columns and similar American wide flange beams can be used in the arches. They give very slender bridges, simple details and little welding. Slender arches look good. Box sections are less slender. Since the arch is so well supported by the hangers, the added stiffness of the box section is not of great value.

The universal columns in the arches should have a horizontal web. Then the buckling strength can be about the same in the plane of the arch and out of the plane of the arch.

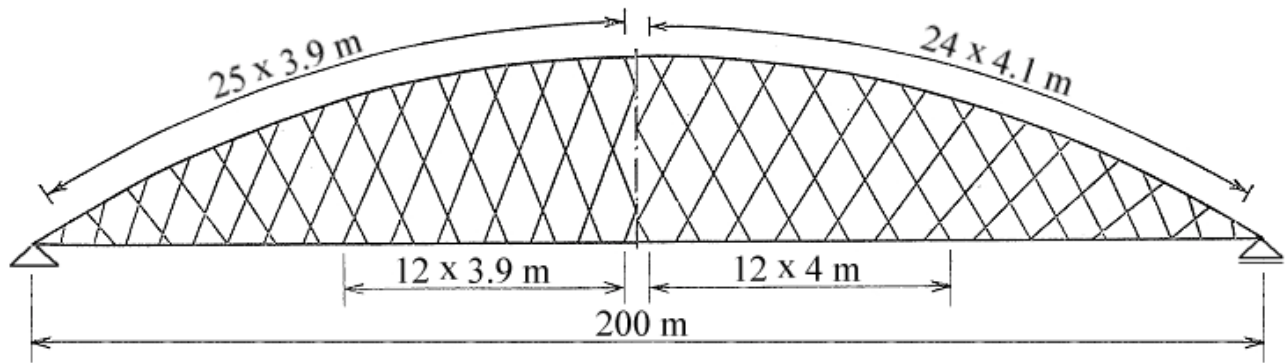

Fig. 3. Skeleton lines for two bridges designed for an IABSE congress in Vienna in 1980.

A network arch can be seen as a simply supported beam. The arch is the compression zone, and the tie is the tension zone. The hangers are the web. Most of the shear force is taken by the vertical component of the compressive force in the arch. Some of the variation in the shear force is taken by the hangers.

The force in the chords can be reduced by increasing the distance between them, but aesthetic considerations limit the rise of the arch. The author thinks that a rise of the arch of about 15 % of the span usually looks best. That is usually the rise of German arch bridges with the arch above the tie. Two American network arches have a rise of 20 % of the span. Most Japanese network arches lie in between.

In network arches some axial forces can not be avoided. The optimal network arch takes these forces as efficiently as possible. The optimal network arch is an efficient structure for the following reasons:

The details are simple, light and highly repetitive. Tension is predominant in the hangers and in the tie. There is little bending in the chords. The arch gets good support from the hangers. Thus there is little tendency for buckling in the plane of the arch. The buckling strength in the arch is high. All members make good use of high strength steel.

The hangers distribute the loads between the chords in such a way that there is very little bending in the chords as long as all or all but a few hangers are in tension. The hanger arrangement on the right side of fig. 3 gives a higher resistance to relaxation of hangers than the hanger arrangement on the left. p. 8. [Tveit 1980]. The hangers can be steel rods or wires. Fig. 4 has the characteristics of optimal network arches.

- *Some hangers cross each other at least twice*
- *There is little bending in the chords*
- *Tension is predominant in the tie and hangers*
- *Compression is predominant in the arch*
- *The arch is well supported in the plane of the arch*
- *High strength steel is well utilized*
- *There are longitudinal prestressing cables in the tie*

Fig. 4. Characteristics of optimal network arches.

By now the fundamental facts about network arches have been established. The rest of the text is on how and why network arches should be built.



Fig. 5. Network arch at Steinkjer. Span 80 m.

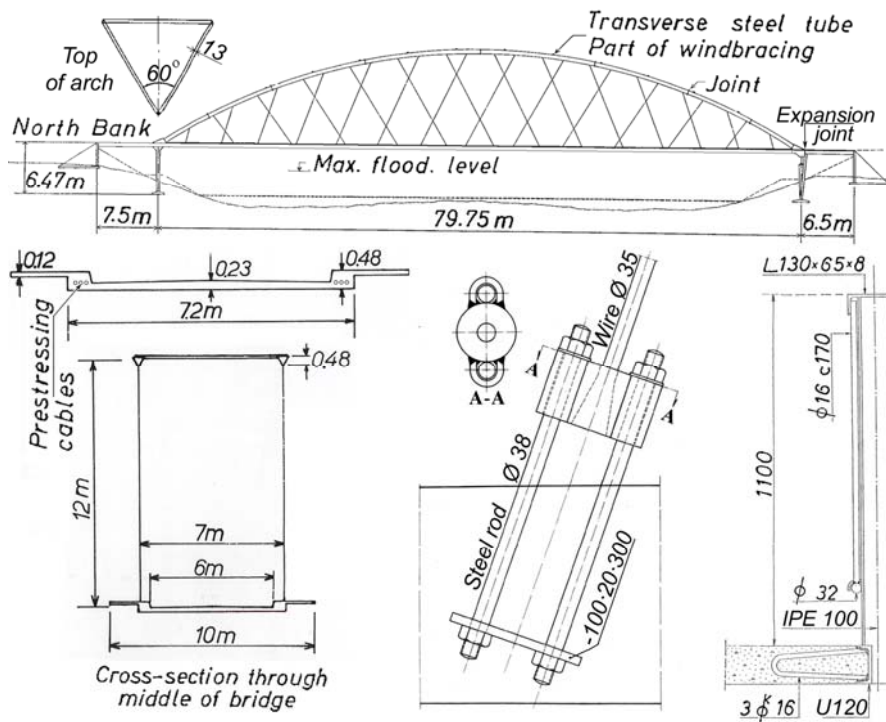

Fig. 6. Details of the network arch at Steinkjer.

The railings are welded to bits of steel channels anchored to the edge of the footpath. The welding here was done slowly with little heat to avoid breaking the bond between steel and concrete. The author was warned against anchoring steel rods in the concrete, but this has functioned well for over 40 years. The slight prestress in the tie has contributed to this.

It was also said that the public would not like to have the railing outside the footpath. The 13 cm (5") wide handrail is supposed to make the pedestrians feel safe. There have been no complaints. The handrail is in one piece along the main span. The railing was put up when the concrete was about half a year old. The author expected the tie to become shorter than the handrail due to shrinkage and creep of the concrete. That has not happened, but the expansion joint has had a tendency to close.

The author's first network arch was built at Steinkjer in Norway in 1963. [p. 5b to 6c] It was a mistake that there were no rails between the hangers and the traffic.

Vehicles have bumped into the hangers, but the damage has been insignificant. Nobody checked the calculations. Maybe that was not sensible, but it made the bridge more original.

Materials per m² of main span: Concrete with a cube strength of 35 MPa 0.22 m³. Structural steel with a yield strength of 355 MPa 60 kg. Reinforcement 40 kg. Prestressing steel 7 kg.

Fig. 6 gives details of the network arch at Steinkjer. Please note the slim chords. The arches have a constant curvature.

The constant change of slope between neighbouring hangers is 1.8°. The slope of the steepest hanger is 74.4°.

The cross-section are the same in all hangers. The maximum force is almost the same in all hangers.

There are prestressing cables in the tie. The hangers are adjustable. They are anchored in the edge beams.

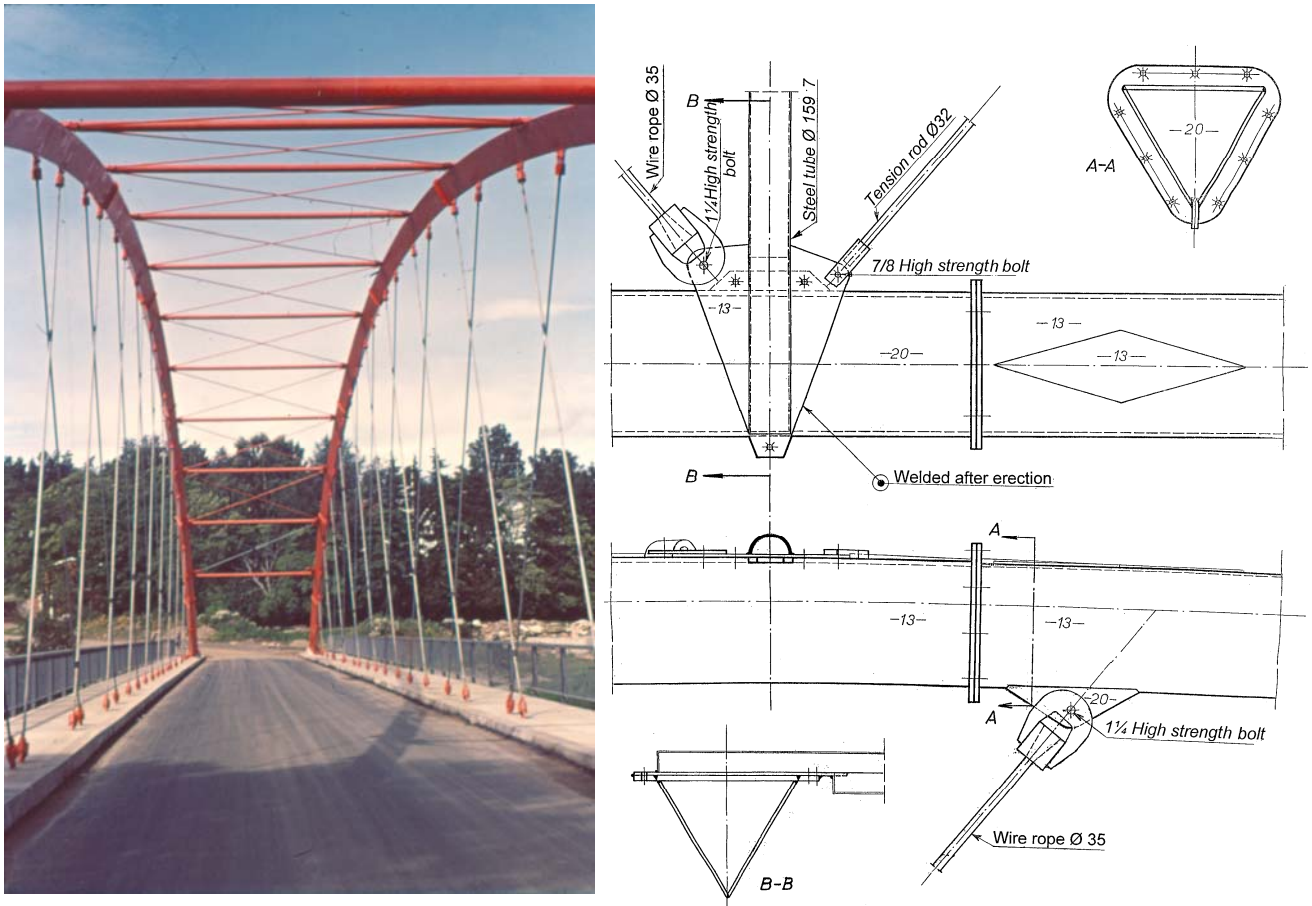

Fig. 7. More details of the network at Steinkjer.

The left side of fig. 7 shows the bridge before it got its final coat of paint. The architect recommended that we should keep the red colour. The author opted for a more conventional silver gray. However, seeing the red colour of Chinese arch bridges has convinced the author that the architect was right.

The architect was very good. At the time we were both assistants at the technical university in Trondheim. He said: "Let your design show how the forces run in the structure". He went on to become a professor of architecture.

The right side of the slide shows more details of the steel structure. See how the upper ends of the hangers are fastened to the arch. Since there is only compression in the cross-section of the arch, the joints are simple flanges. The screws in the flanges are needed only during the erection. Because of the high redundancy, the network arch can take failure of a lot of hangers. [Zoli and Woodward 2005]

Details around the second tube in the windbracing are shown in fig. 7. The first diagonals in the windbracing have the same details as a hanger. The other diagonals in the windbracing are tension rods that have been tightened by thread bars.

The first tube in the windbracing has a smaller maximum force than the second. The two tubes have the same cross-section because a high load might collide with the first tube. This has actually happened, but the bridge was not in danger of collapsing. The damage was not serious, and it was easy to repair.

The steel structure looks good and was simple to erect, but it was costly to make. Still the network arch was less costly than a competing concrete arch with vertical hangers. If the arches had been universal columns or American wide flange beams, the cost would have been much reduced.

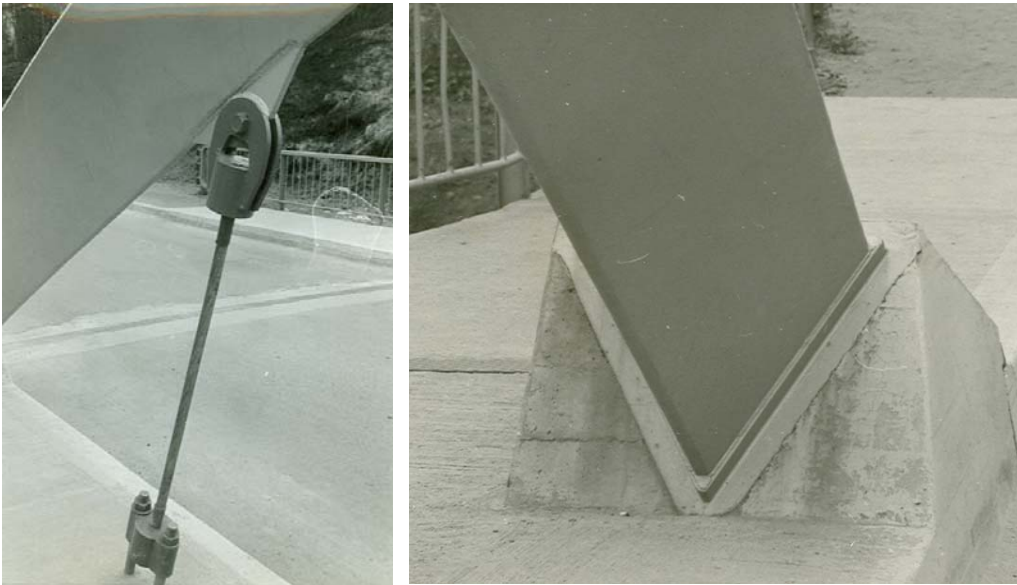

Fig. 8. Hanger and end of arch at Steinkjer.

The left side of fig. 8 shows a hanger and the end of the network arch in Steinkjer.

At the lower end of the hanger the decisive cross-section is under the nuts.

Thus the steel rods have ample cross-section just above the concrete. They can take the bending due to colliding vehicles.

Five hangers have been hit by vehicles. The damage is not serious, but it is best not to bend them back. That would increase any damage to the concrete where the hangers enter.

The right side of fig. 8 shows the lower end of an arch. The lowest 7 m of the arch is filled with concrete to make it more able to withstand collision with heavy vehicles.

Fig. 9 shows a moveable bearing for the network arch at Steinkjer. The prestressing cables are anchored to the plate at the end of the arch. The plate below is as if it was cut out of a cylinder. That makes a roller bearing. The steel plate was checked for lamination.

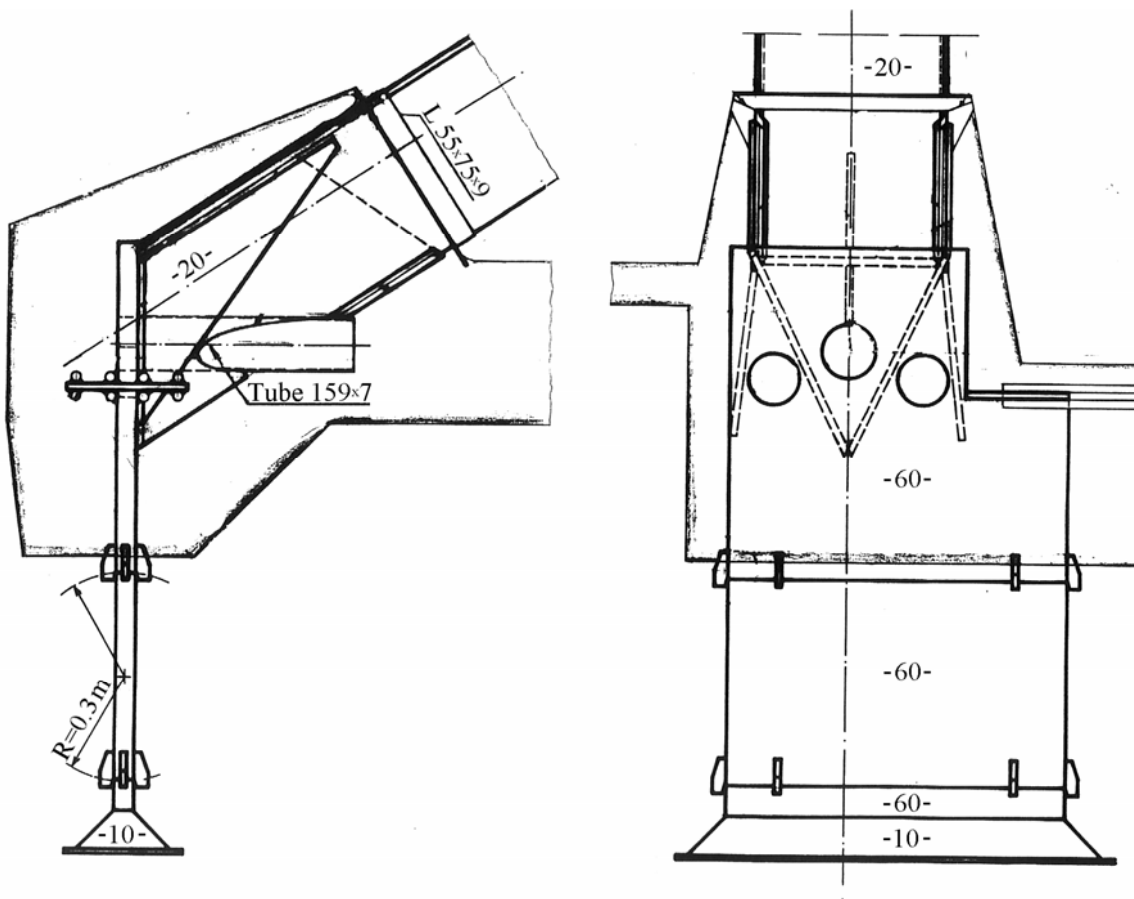
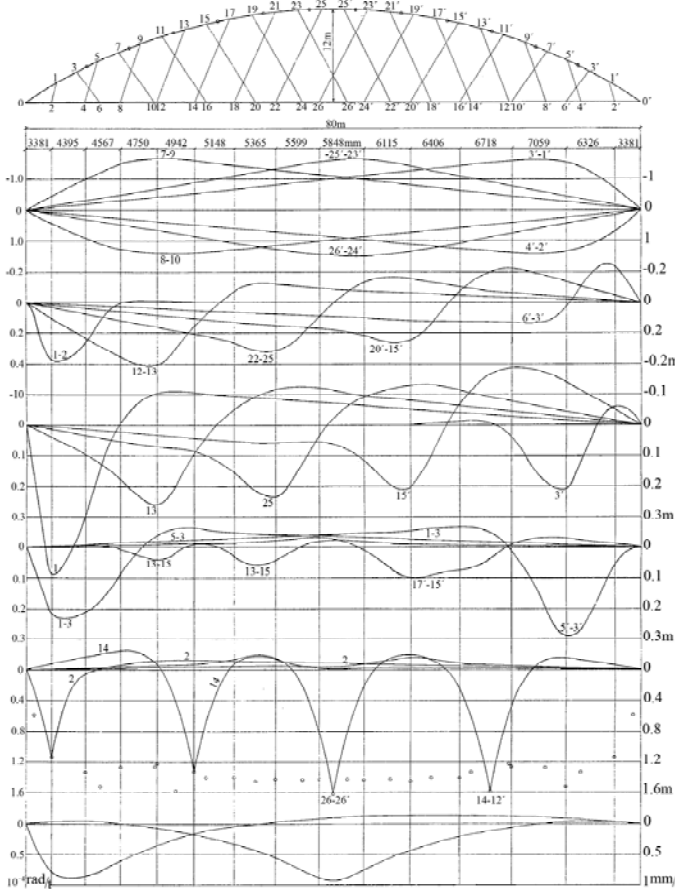

Fig. 9. Moveable bearing for the network arch at Steinkjer.

Influence lines for the network arch at Steinkjer



The slope of the steepest hanger is 74.4°. The difference in the slope between two adjoining hangers is 1.8°.

Compression in arch

Tension in tie

Force in hangers

Bending moments at nodal points in arch

Bending points in the middle of members in arch

Bending moments in tie

Rotation at the end of the tie

Deflection of tie at the middle of span

Fig. 10 shows influence lines at Steinkjer.

Here are the influence lines for the network arch at Steinkjer. p. 57. Their shape is very much like the influence lines of a truss. In fact the network arch can be seen as a truss with many diagonals that can only take tension. We can see that the axial forces in the arch and lane are very constant. So are the longitudinal bending moments in the tie.

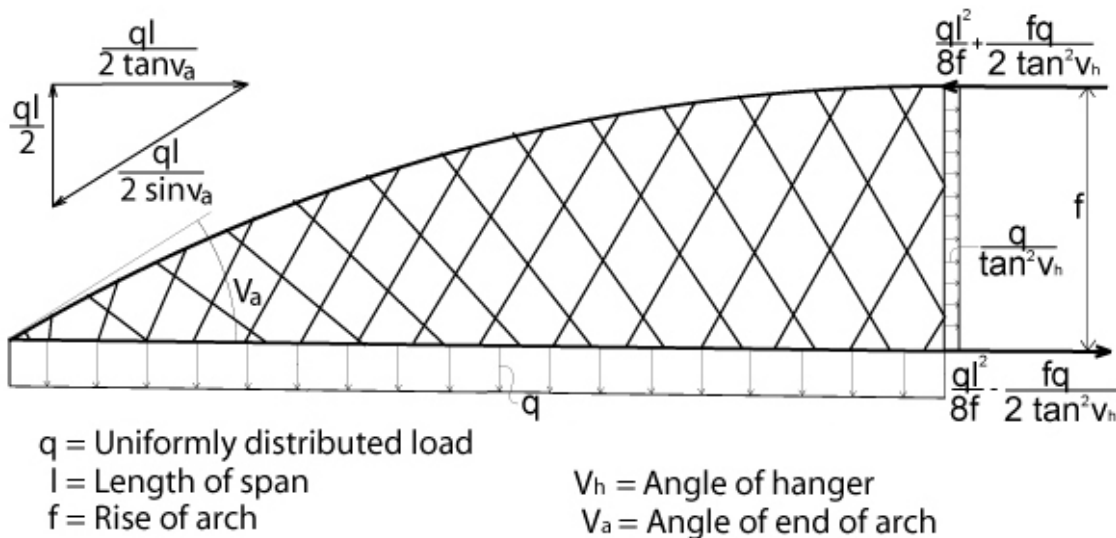

Fig. 11. Axial forces in network arches.

Fig. 11 gives formulas for axial forces in a network arch due to an evenly distributed load. p. 5a. Bending moments have rightly been disregarded. The forces at the end of the arch are obvious. In the middle of the span the hanger forces add a little to the axial force in the arch and subtract a little from the tension in the tie.

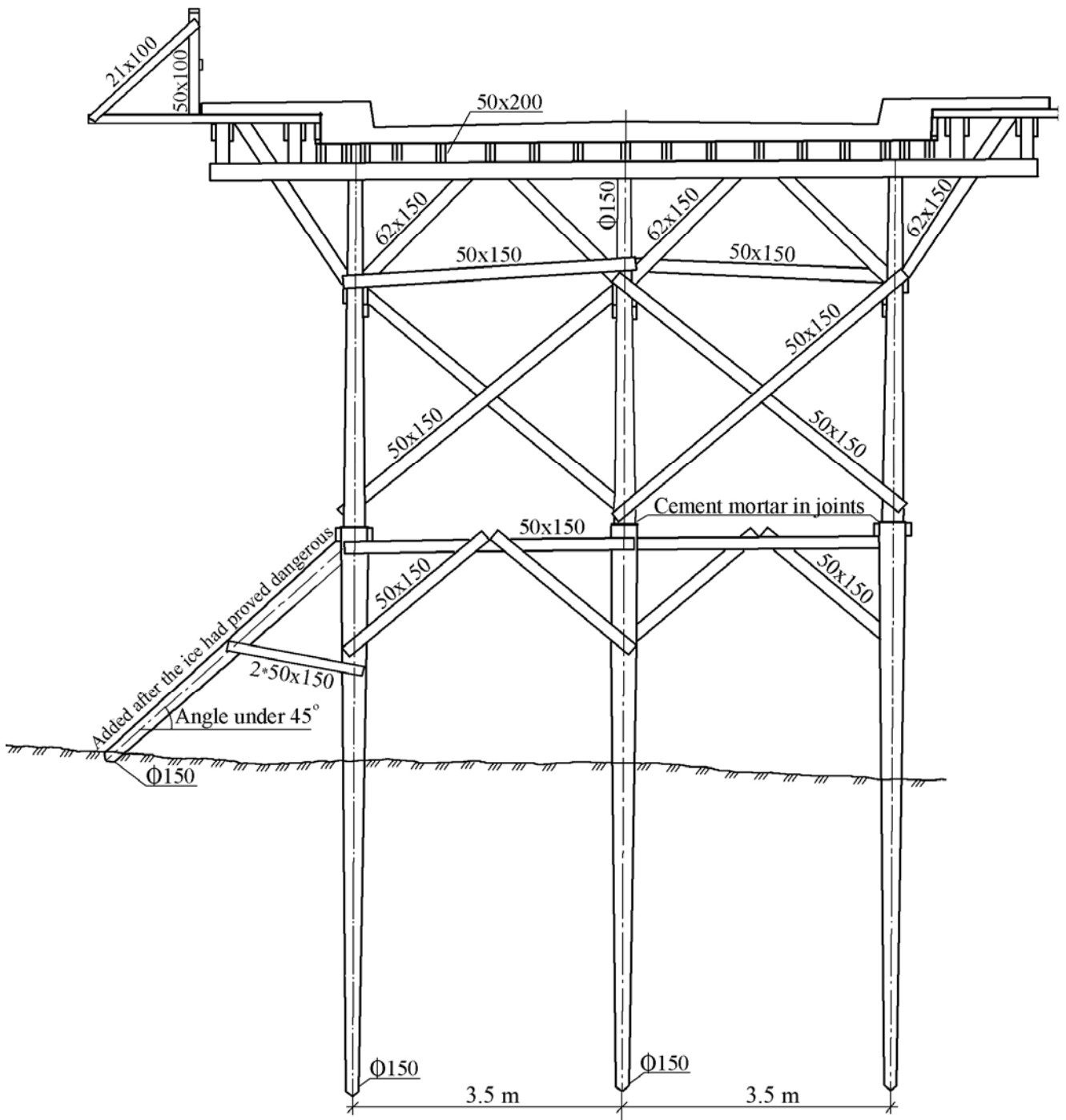
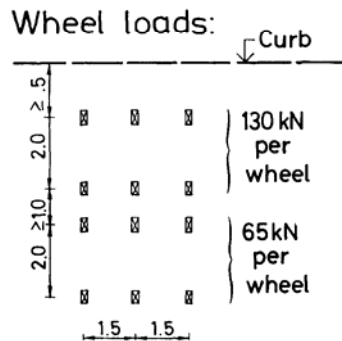
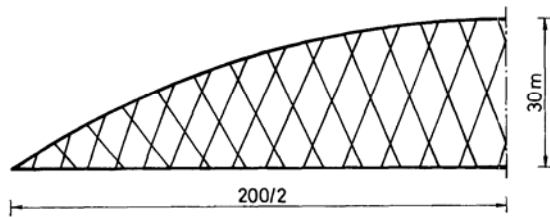

Fig. 12. Scaffolding for the network arch at Steinkjer.

Fig. 12 shows the scaffolding for the network arch at Steinkjer. p. 6b. After the concrete tie was cast, the arch was supposed to be erected. Then the hangers were supposed to be installed and tensioned till they carried the tie. Then the wooden scaffolding could be removed.

The steel did not come as planned and in the winter the ice swept away 17.5 m of the scaffolding. It was most unpleasant. The tie was sagging about 0.2 m. Cracks of up to 2 mm appeared. They closed again due to the prestressing. Now they can hardly be found. The network arch at Steinkjer is in good shape after 44 years. Given good maintenance it is likely to last at least twice as long.

Network arch, proposal 1980. Danish codes.



Evenly distributed load:
Between traffic rails 2.5 kN/m^2
Sidewalks: 2.5 kN/m
Cylindrical strength of concrete 40 MPa

Measurements in metres

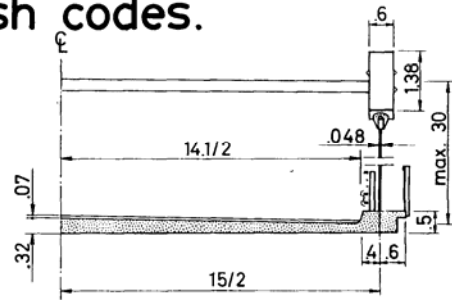

Concrete $4.5 \text{ m}^2/\text{m}$

Ribbed bars 62 t
Prestressed steel 192 t
Wire for hangers 53 t
Structural steel 363 t
 $\Sigma 670 \text{ t}$

Bridge at Straubing, built 1977. Codes: DIN

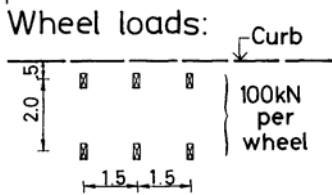
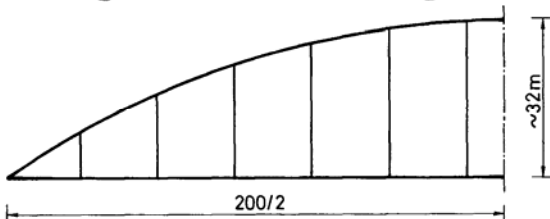

Evenly distributed load:
Main lane
 $3 \text{ m wide } 5 \text{ kN/m}^2$
Rest of the bridge
 3 kN/m^2

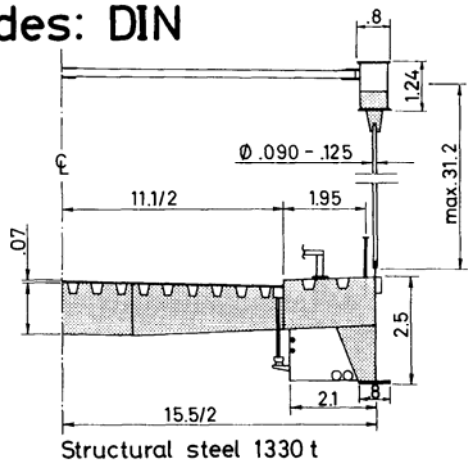

Structural steel 1330 t

Fig. 13. Information on two arch bridges.

Fig. 13. gives some information on a network arch and an arch bridge with vertical hangers that were built in southern Germany in 1997. The two bridges have nearly the same width and both have spans of 200 m.

Fig. 14 on the next page shows influence lines for longitudinal bending moments in the chords of the two bridges in fig. 13. [p. 13 and 14]. The ordinates are much smaller in the network arch, especially in the tie, because the tie in the network arch is very slender.

The two bridges have different codes and rise of the arches. Still they can be compared. The bridge with vertical hangers uses twice as much steel as the network arch. This is impressive since the Straubing Bridge uses no concrete.

The biggest influence ordinate for the tie in the network arch is 1.4 m [p. 14]. That is the same as for a simply supported beam spanning 5.6 m. Thus the biggest bending moment in the tie is normally in the middle of the concrete slab spanning 15 m between the arches. In most network arches the bending moment halfway in the arches is bigger than the longitudinal moment in the tie. For spans under 150 m the shape of the slab tie is usually independent of the span. There is no need for longitudinal steel beams in the tie.

The author believes that the arch of the Straubing Bridge, [Stein and Wild 1965], should have been part of a circle. Then the wind portal would have been shorter and the bending moments in the chords would have been more even furthermore, the axial force would have been smaller and more even in the middle 2/3 of the arch. The constant curvature of the arch would have made production simpler.

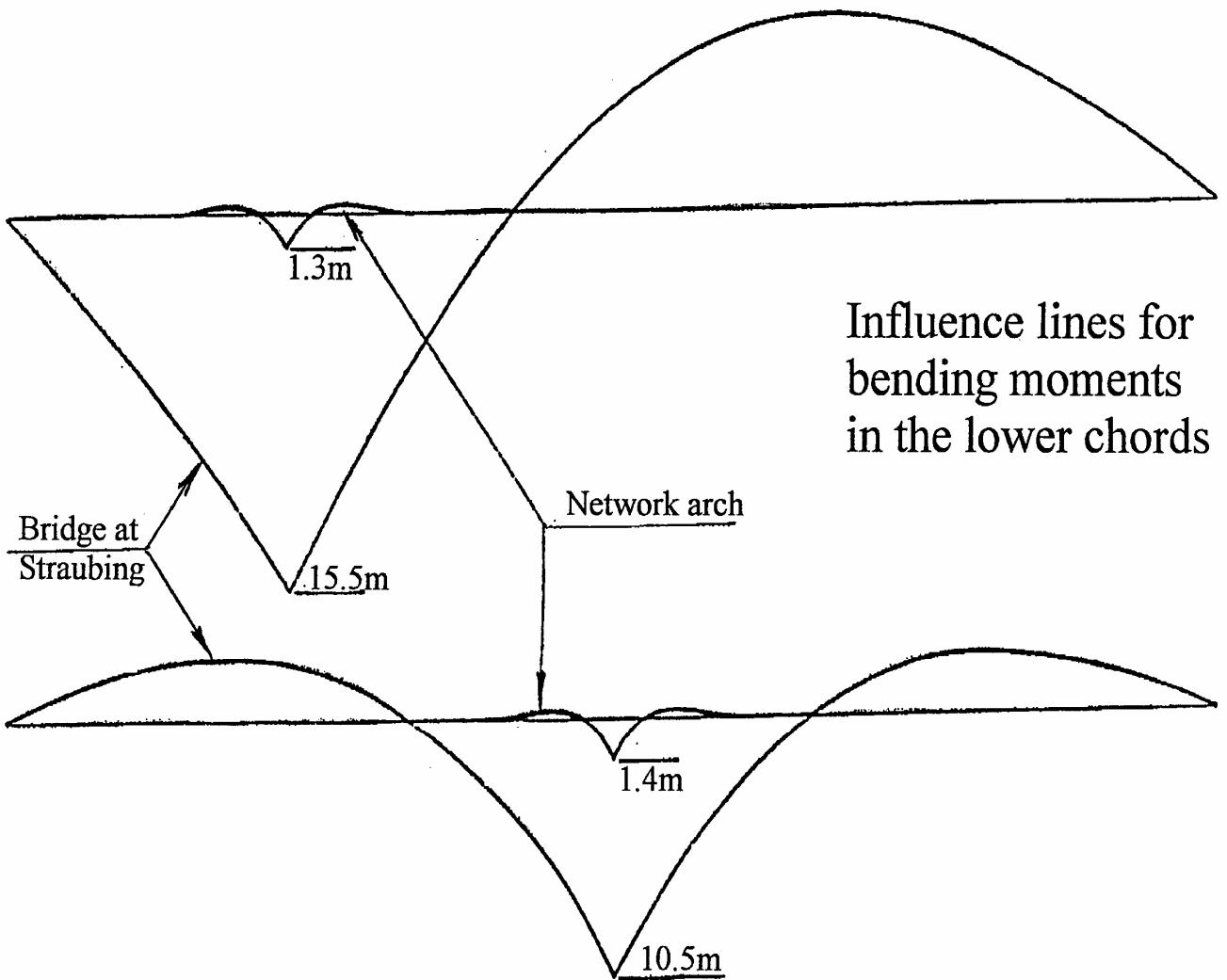
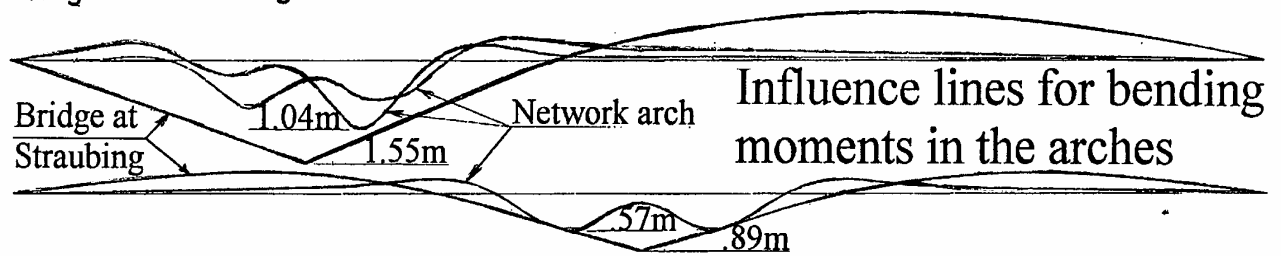
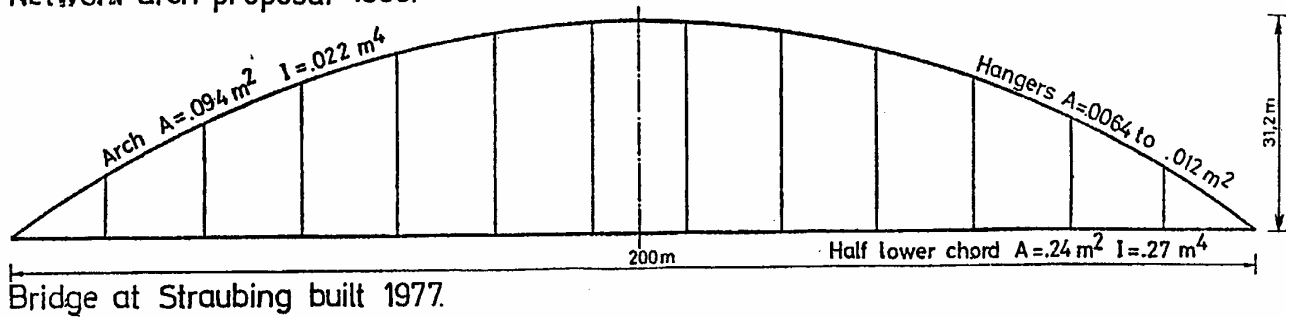
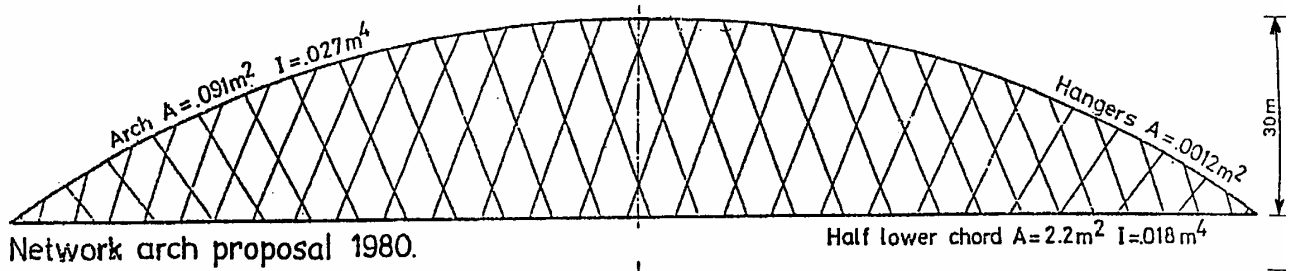
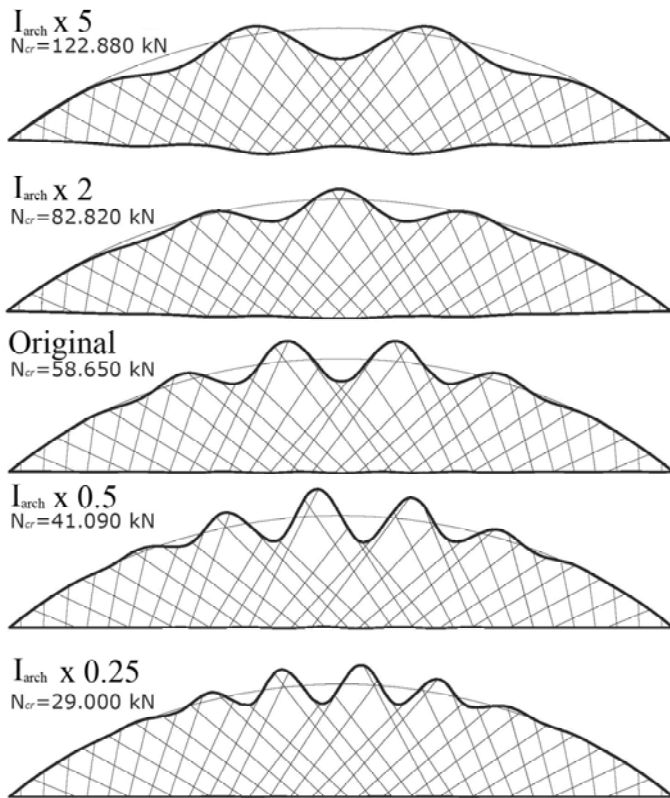

Fig. 14. Influence lines for the two arch bridges in fig. 13.



Stiffer arches

F. Schanack

Examples of buckling

Less stiff arches

Fig. 15. Buckling of network arches.

Fig. 15 shows how buckling in the plane of a network arch changes with the stiffness of the arch. The buckling will normally be calculated by advanced computer programs [Schanack 2008]. When the arch has a rectangular cross-section, the buckling in the plane of the arch is usually not decisive.

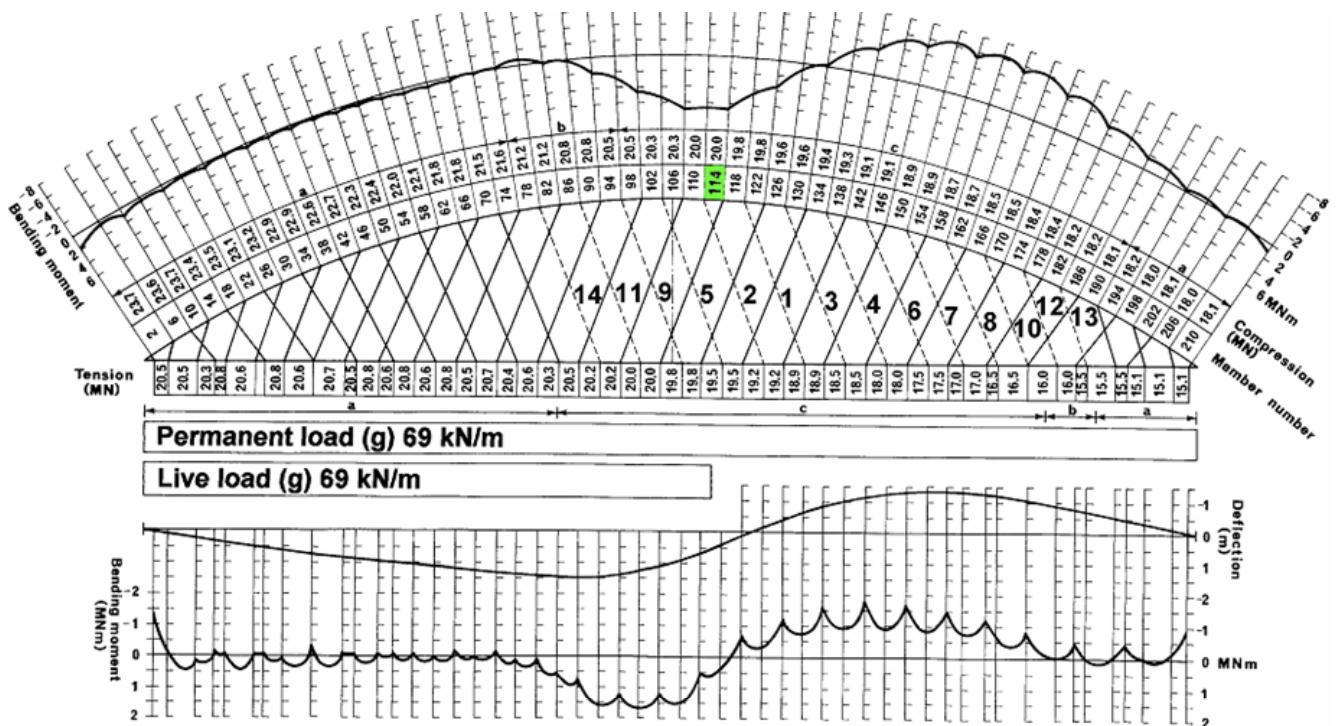

Fig. 16. Relaxation due to skew loads.

Fig. 16 shows the effect of hangers relaxing [p. 67 and 68]. Numbers indicate the sequence of the relaxation of the hangers. The calculations have been done for a live load equal to the dead load. This equality is, however, not likely to occur.

Moderate skew live loads that make a couple of hangers relax are not dangerous because reduced axial forces compensate for the increased bending moments. The relaxation of hangers gives reduced buckling stresses in the arch, but in these cases that is not likely to be dangerous.

Widespread relaxation of hangers leads to increased deflection and considerable bending moments in the chords. Where the hangers have not relaxed, the bending moments in the chords are small.

Arch member 114 is the first member where an increasing skew load gives the same maximum stress as the load on the whole span.

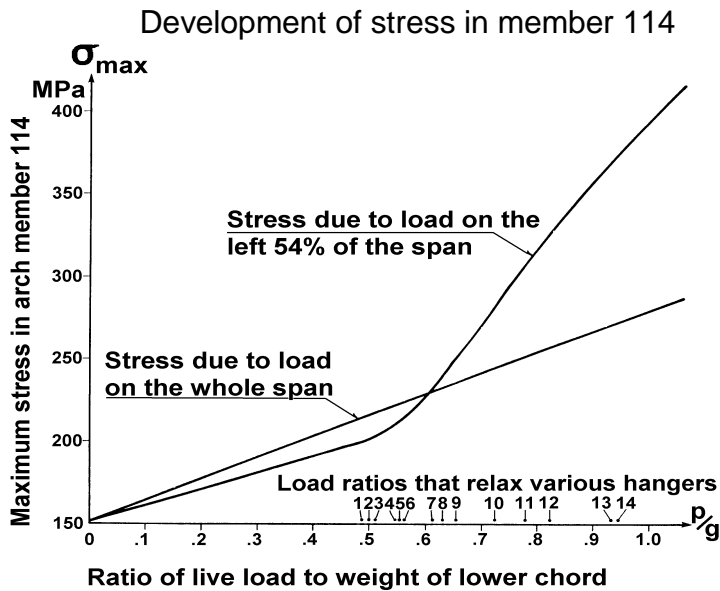

Fig. 17 shows the development of maximum stress in member 114. Along the horizontal axis is the ratio of live load to dead load. You can see the ratios of live load to dead that make various hangers relax.

For moderate live loads, load on the whole span is decisive. After six hangers have relaxed, partial live loads start to give the maximum stress.

For slim network arches, it is best to avoid the relaxation of hangers in the serviceability limit state. It simplifies calculations and gives less fatigue in hangers if relaxation of hangers is avoided also in the collapse limit state.

Fig. 17. Maximum stress in member 114 in fig. 17.

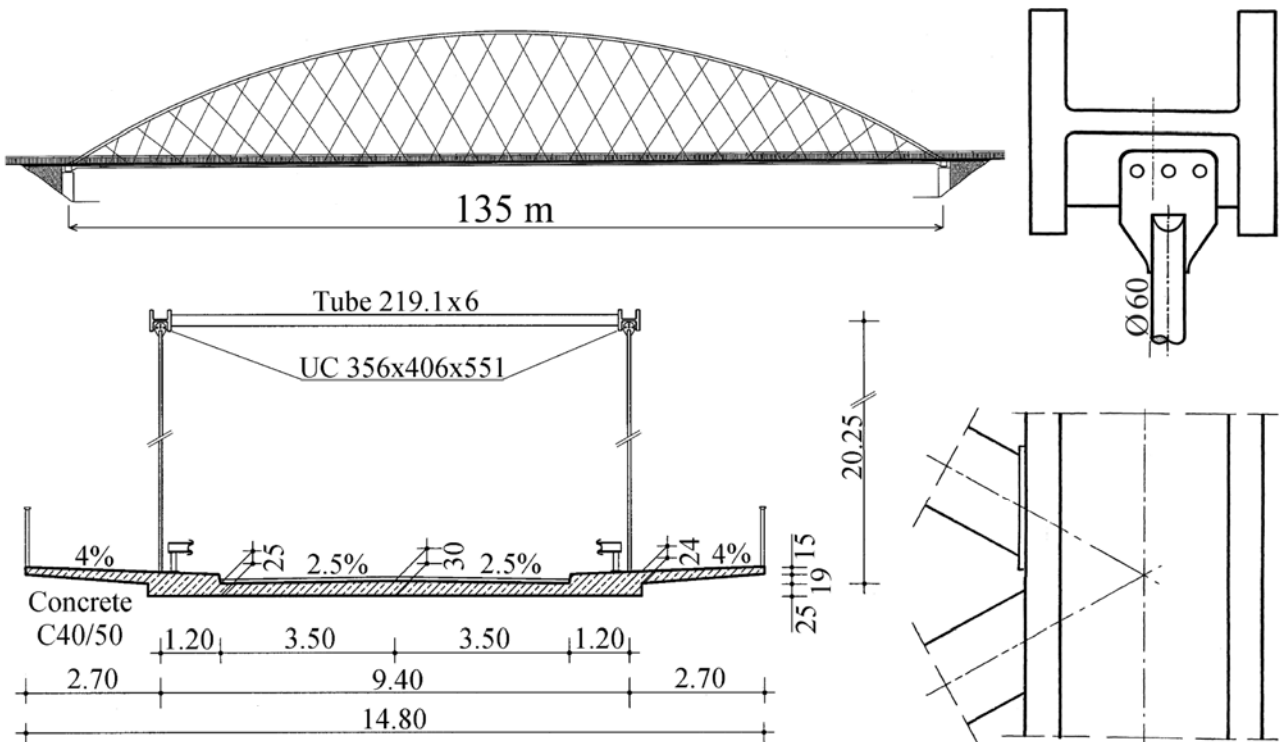

Fig. 18. A network arch between two Norwegian islands.

A good example of an optimal network arch is shown in fig. 18. It was designed by Teich and Wendelin in 2001 [Teich and Wendelin 2001], two students from TU-Dresden in Germany. They did their master's with the author in Norway and received a prize for outstanding master's thesis at their university. One of the students, Mr Teich, will defend his doctoral thesis on network arches in 2008.

EU loads and codes were used. When in doubt solutions that resulted in bigger steel weight were usually adopted. The bridge was planned between two Norwegian islands with a total population of 3500 inhabitants. The foreseeable volume of traffic is so little that fatigue was no problem.

The arch is part of a circle. The hangers are placed equidistantly along the arch. Two ways of fastening the diagonals between the arches are shown. Steel with a yield stress of 430 MPa has been assumed.

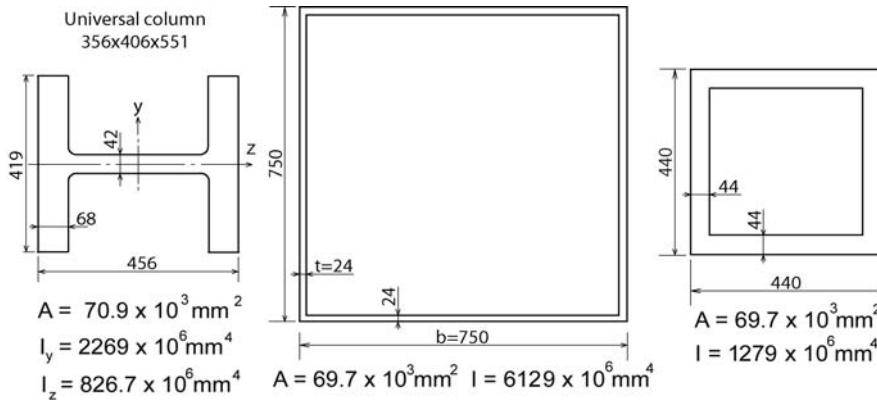

Fig. 19 shows the cross-section of the universal column used in the middle of the bridge in the previous slide and two box sections with the same area.

It is meant to illustrate the pros and cons of the choice of universal columns and boxes in arches of network arches.

The middle section in the slide is 64 % wider with a

Fig. 19. A comparison between universal columns and box sections.

moment of inertia that is 2.7 times the biggest value for the universal column. The advantages of the universal column are the smaller amount of welding, smaller dimensions and simpler details. The cross-section to the right has the same visual diagonal as the universal column, but is otherwise not practical. The author prefers the slim looks of network arches with universal columns or similar American wide flange beams in the arches.

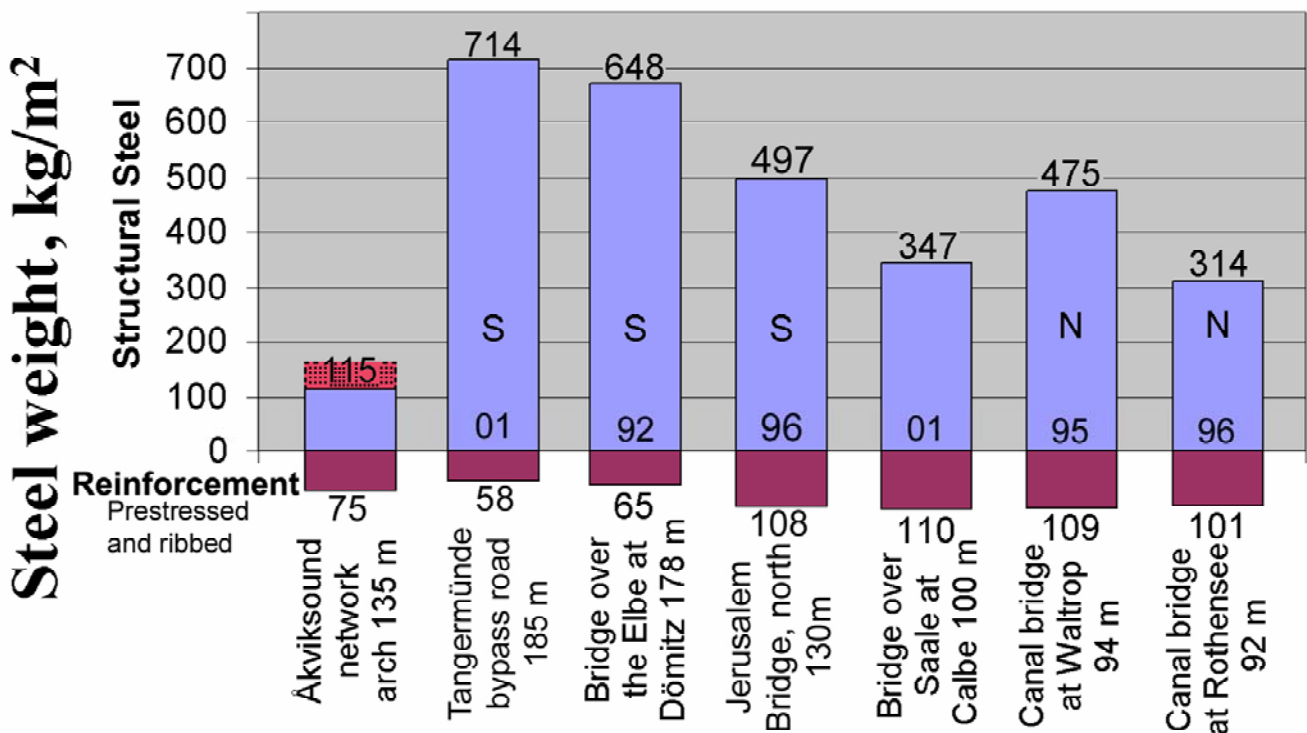

Fig. 20. Comparison of steel weights in some arch bridges.

In fig. 20 the steel weight of the students' network arch in fig. 18 is compared to the steel weight in German arch bridges with vertical hangers. The spans and the years when the bridges were built are indicated. N means that there is no windbracing. S means that the arches slope towards each other.

The German bridges have steel beams in the tie. Still the network arch uses about the same amount of reinforcement without steel beams in the tie. Part of the reason for this is the high amount of minimum

reinforcement that is needed in the concrete on top of the elongating steel beams. The cracks over the elongated beams give higher maintenance costs.

The dotted area at the top of the Åkviksund steel weight indicates extra steel weight if a temporary lower chord is used for the erection of the bridge. nevertheless the network arch uses much less steel than the arch bridges with vertical hangers. The steel weight in the temporary lower chord costs less than the rest of the steel because the lower chord needs no corrosion protection. Later we are going to compare the cost of the Calbe Bridge to the cost of a network arch of the Åkviksund type.

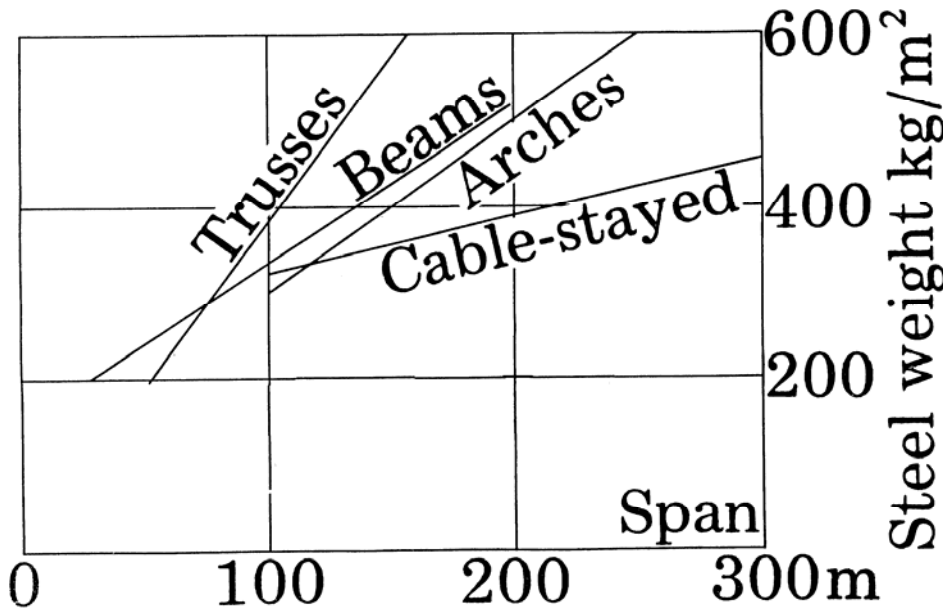

According to an extensive survey by [Herzog 1975] most other steel bridges use more steel than arch bridges with vertical hangers. See fig. 21.

You are right in thinking that steel weight is not the only thing that matters. Let us look at other factors.

Fig. 21. Steel in various bridge types.

Differences between arch bridges with vertical hangers and network arches

<p>Aesthetics</p> <p>Adaptability</p> <p>Fabrication</p> <p>Corrosion protection</p> <p>Maintenance</p> <p>Erection</p> <ul style="list-style-type: none"> • On sidespans • Floating into place • Erection on ice 	<p>Bulkier bridges</p> <p>2 to 8 times deeper lower chords</p> <p>15 to 30 times longer welds</p> <p>More complicated details</p> <p>3 to 7 times more surface to protect</p> <p>Other concrete parts need much more maintenance than concrete slabs with a slight prestress.</p> <p>Erection is more expensive with 2 to 4 times more steel</p>
--	---

Fig. 22. Comparison between network arches and arch bridges with vertical hangers. p. 96.

In fig. 23 the Calbe Bridge is compared to a network arch of the Åkviksund type spanning 150 m. The network arch has longer spans because its steel weight is smaller and increases more slowly with an increased span. p. 93a to 93b.

Material and cost of the Calbe Bridge compared to that of a network arch

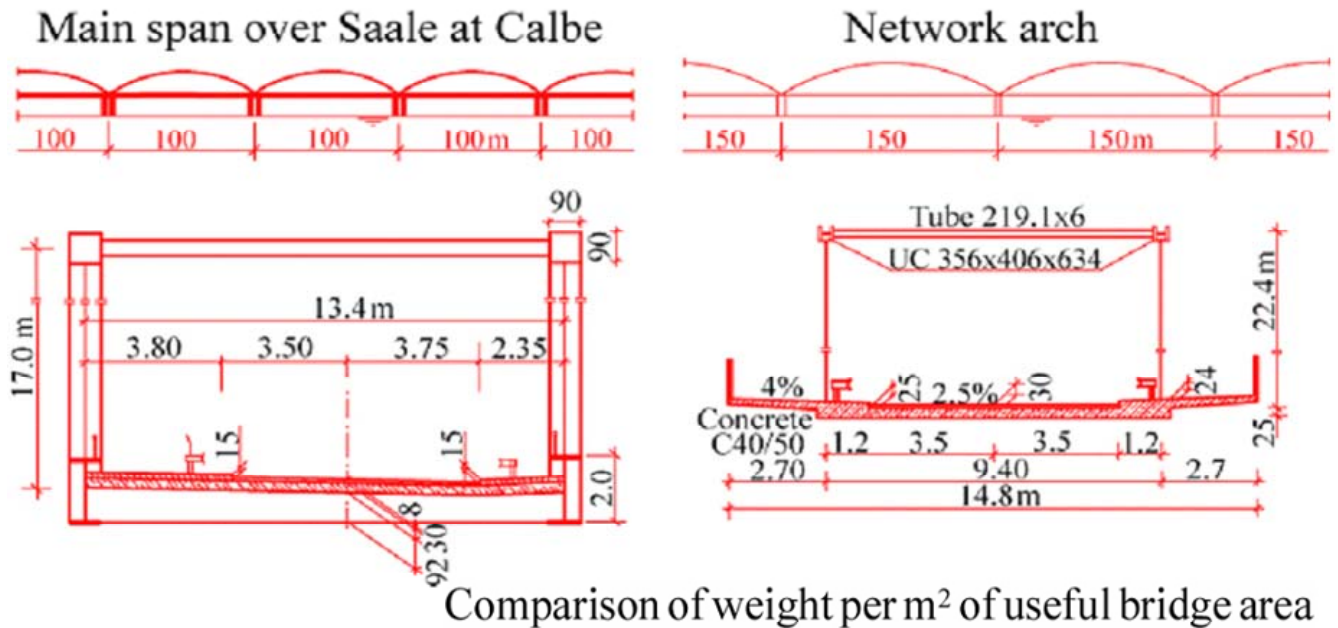

Comparison of weight per m² of useful bridge area

58 % of the structural steel is saved

34 % of the reinforcement is saved

24 % of the concrete is saved

Less weight has to be moved during erection

The pillars are the same for both bridges.

The saving on cost is probably 35 to 45% per m² of useful bridge area.

Fig. 23. Comparison between the Calbe Bridge and a network arch.

Many good civil engineers will be inclined to believe that these savings are exaggerations. The author thinks it would be stupid to exaggerate since the bare facts seem like an exaggeration. There can be no doubt that the network arch is worth examining more closely.

Since the arch in network arches has mainly axial forces, should we not make the arch of concrete? We should if the cost of formwork is not too big. In long bridges with many spans all the concrete spans could be made on the shore and then be floated to the pillars. p. 47 to 50.

The author has made a comparison between the built western part of the Great Belt Bridge in Denmark and an alternative using a network arch. p. 50. See next page.



Max. weight of beam element to be moved:	5800 t	to	< 4000 t
Weight of concrete per m:	45 to 55 % reduction		
Weight of reinforcement per m:	25 to 50 % reduction		
Bridge piers per m:	50 % reduction		
Forces on bridge pillars per m:	45 to 55 % reduction		
Cylinder strength of concrete in tie.	Increase from 55MPa to 55-65MPa		
Cylinder strength in arches:	140 MPa		
Price of substructure:	25 to 50 % reduction		
Price of superstructure:	20 to 40 % reduction		

Saving in costs: 25 to 35 %

Fig. 24. Comparison of two bridges made of concrete.

Now I will go back to the beginning.

After my graduation I got a grant to study for one year at the technical university in Aachen in Germany. Network arches took up most of my time. Nobody else seemed interested in arch bridges with inclined hangers. Professor Phillip Stein was very good to me. He helped me to get an opportunity to build my first model of a network arch. He seemed relieved and slightly surprised at how well the model tests supported my ideas on the relaxation of hangers.

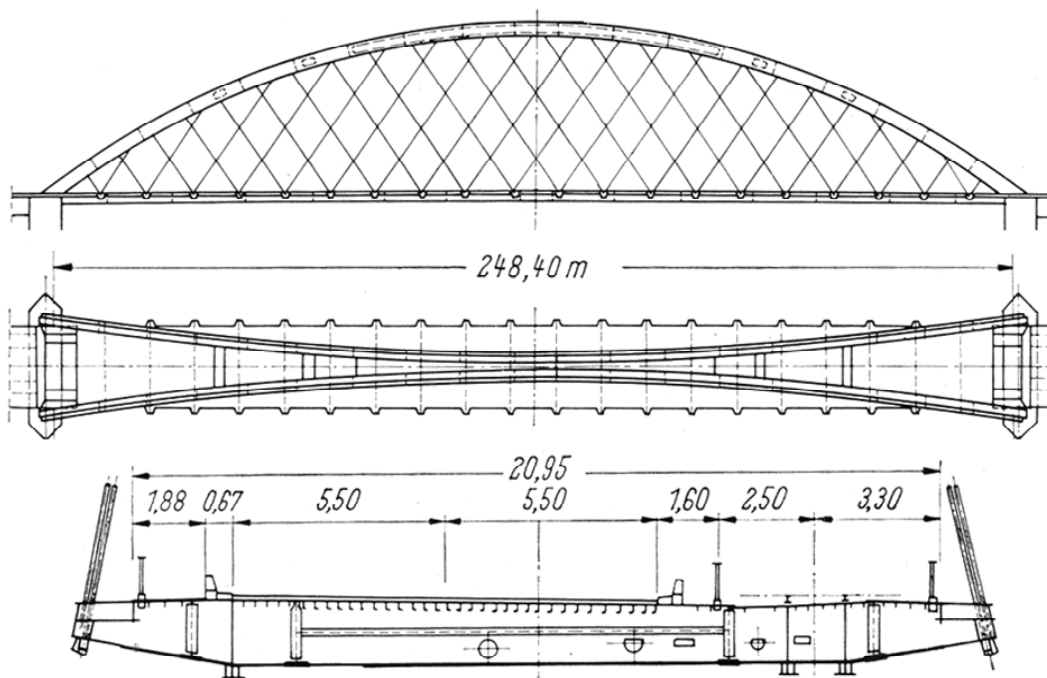

The Fehmarn Sound Bridge, Germany. 1964

Fig. 25. The Fehmarn Sound Bridge. Span 248 m.

The bridge in fig. 25, [Stein and Wild 1965], was finished in the same year as the author's two Norwegian network arches [Tveit 1964 and 66]. At first the author thought that it was a coincidence that the Fehmarn Sound Bridge was a network arch. Later he found that Professor Stein had written the 100 years history of the firm, Gutehoffnungshütte, that built this bridge. p. 90. In a letter Professor Stein confirmed that he may have transferred the idea of the inclined hangers to Gutehoffnungshütte.

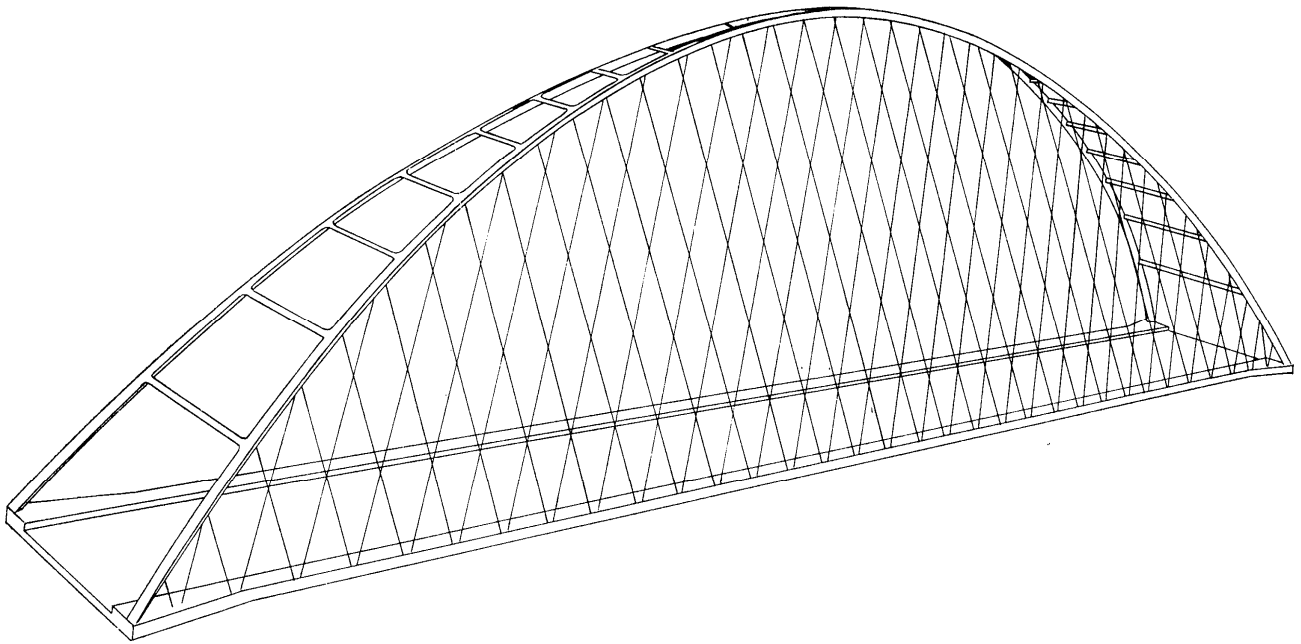

Fig. 26. Bridge suggested in the author's Ph.D. thesis in 1959.

The bridge in fig. 26 is from the author's doctoral thesis in 1959. [Tveit 1959]. Here the arches slope towards each other. If all the hangers had been drawn, the sloping arches would have given a more disturbed pattern of the hangers.

The sloping hangers reduce the windbracing and the bending in the wind-portal, but they increase the span of the slab or the transverse beams in the tie. The sloping arches lead to increased steel weight. At that time the author still suggested that two hangers meet in the same point and a constant slope of the hangers. Today he would try to avoid that. p. 90.

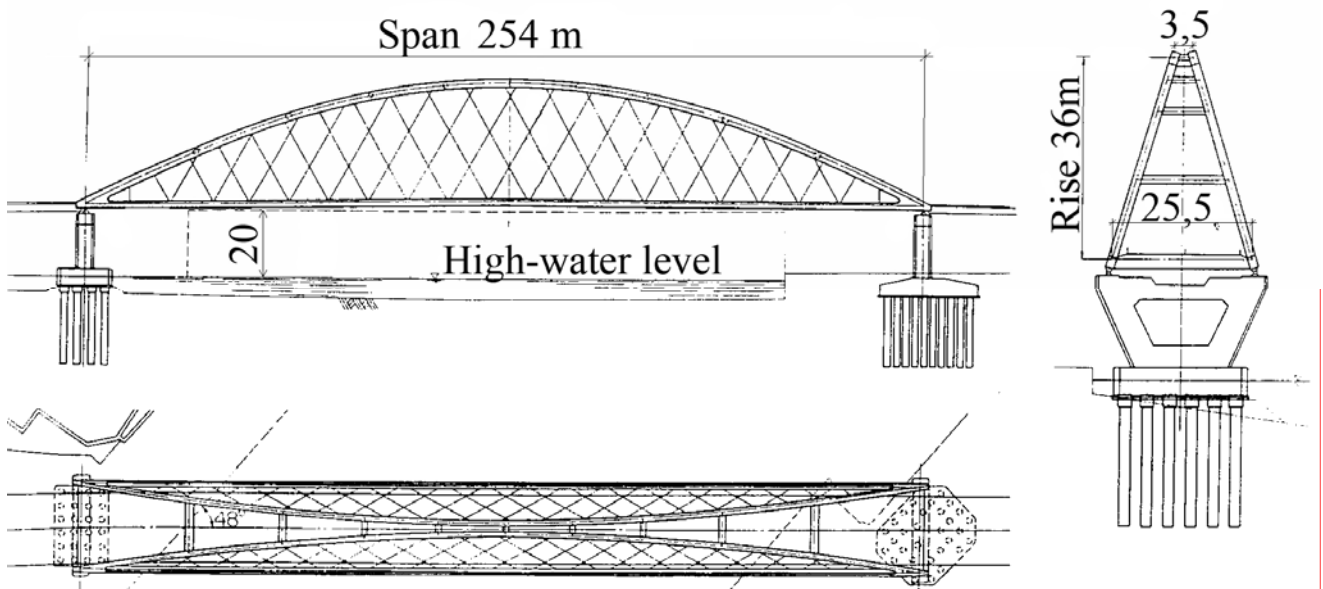
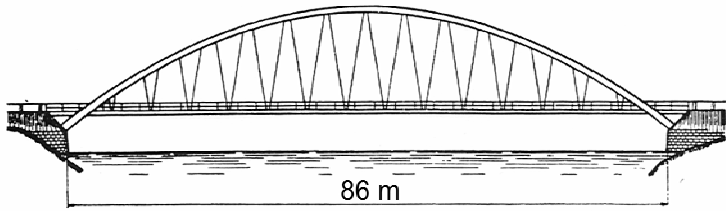
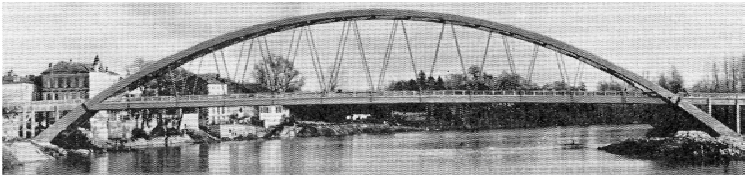

Fig. 27. The Shinhamadera Bridge. Built in 1991. Span 254m.

Professor Masao Narouka saw model tests of the Fehmarn Sound Bridge in TH-Hannover in 1960. [Naruoka et al. 1977] He took the idea to Japan where it has been flourishing. From there it has spread to other countries. The Shinhamadera Bridge, fig. 27, is the longest bridge of this type. p.18. The Japanese call these bridges “Nielsen-Lohse bridges”. The name Nielsen Bridge seems a bit misplaced to the author.



An early Nielsen bridge. Built in Sweden before 1930.



The longest Nielsen bridge. Castelmoron 1933. Span 145 m.

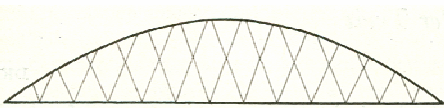

Nielsen never crossed the hangers of his bridges, but in 1926 in a patent document he showed crossing hangers

Fig. 28. Nielsen Bridges

Nielsen used transverse beams in his bridges. That is why there are two hangers in each nodal point in the tie. Nielsen never crossed the hangers in his bridges, but in his patent document from 1926 he showed crossing hangers. Thus the author thinks that arch bridges with inclined hangers that cross each other no more than once should be called Nielsen bridges. The bridge in Castelmoron, France, was the longest Nielsen Bridge till 1963.

In his master's thesis [Tveit 1955] the author suggested that the hangers should cross each other many times. That was a good idea because the loads had increased and the stronger materials had led to more slender chords.

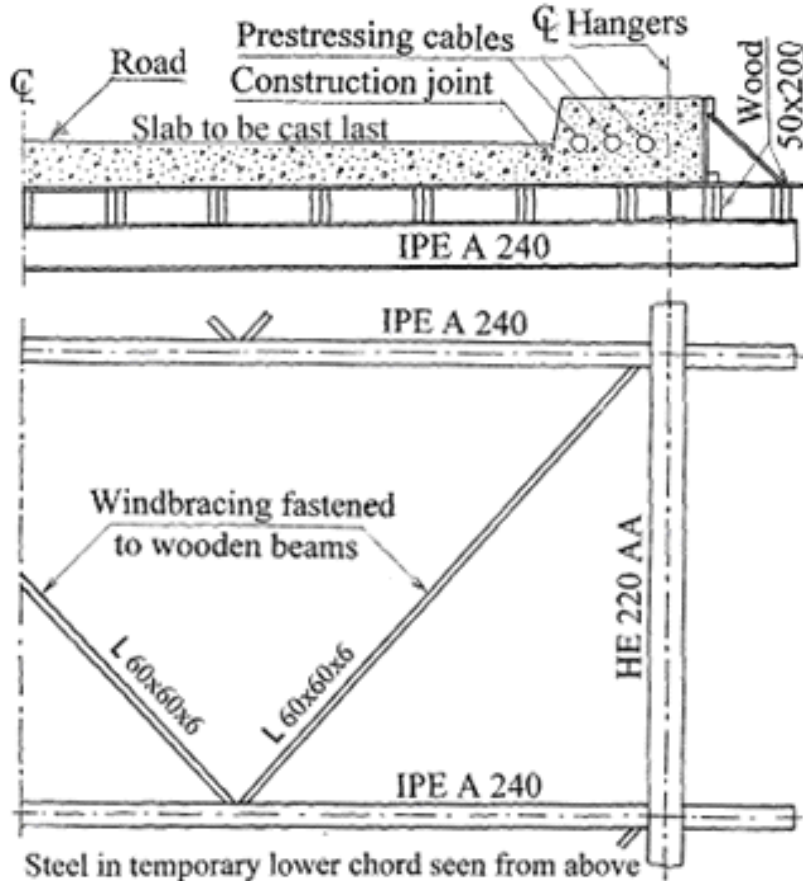

Fig. 29. Temporary tie for network arches.

Fig. 28 shows two Nielsen Bridges. Around 60 Nielsen bridges were built in Sweden between the two world wars. [Ostenfeld 1976], [Nielsen 1932].

Part of my master's thesis was on the calculation of these bridges where hangers could relax. p. 54. That was a difficult task before advanced computer programs were available. In his doctoral thesis in 1929 O. F. Nielsen [Nielsen 1929] explained how to do it. Constant slope of hangers simplified the calculations. Crossing hangers would have made the calculations much more difficult. The hangers were supposed to relax due to ordinary loads.

Fig. 29 shows a temporary tie for the erection of network arches. p. 12, p. 29k to 30a and p. 52 to 53a. Combined with arches and hangers it makes a stiff steel skeleton that can be moved.

The steel skeleton can carry the casting of the concrete tie. First the concrete is cast around the curved parts of the prestressing cables at the ends of the tie.

After that a slight prestress can reduce the stress in the longitudinal beams in the tie. Then the edge beams are cast and then the slab. The casting must be done from both sides to avoid a relaxation of hangers that can lead to big deflections. Then the concrete slab is cast.

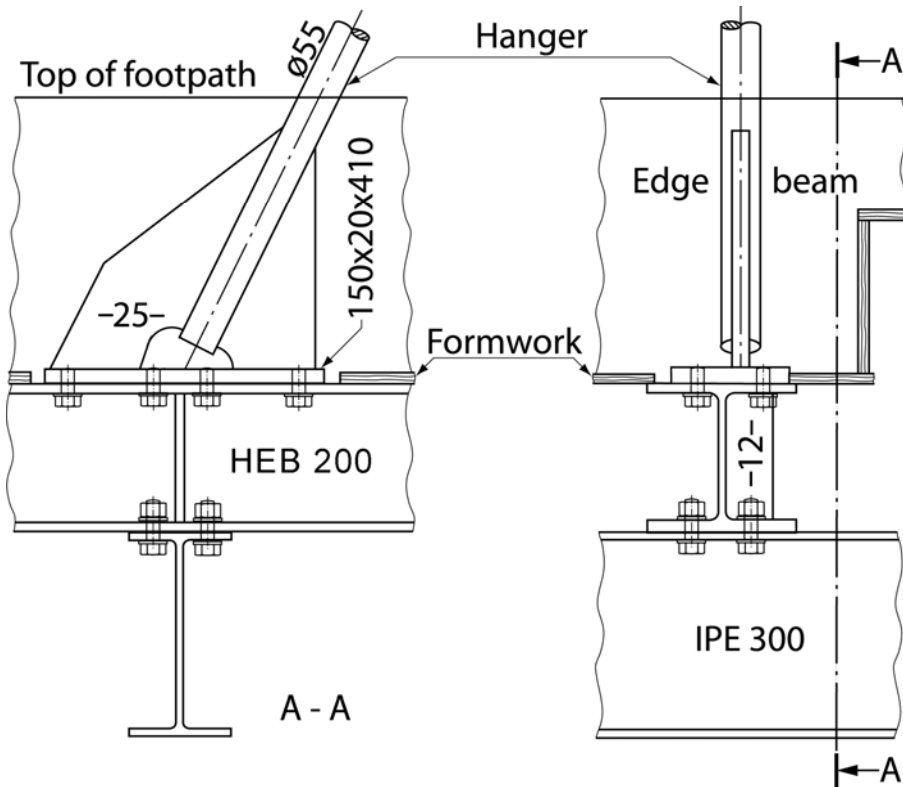

Fig. 30 shows the simple nodal point in a temporary lower chord where the hangers are steel rods. p. 12.

Fig. 30. Nodal point in a temporary tie.

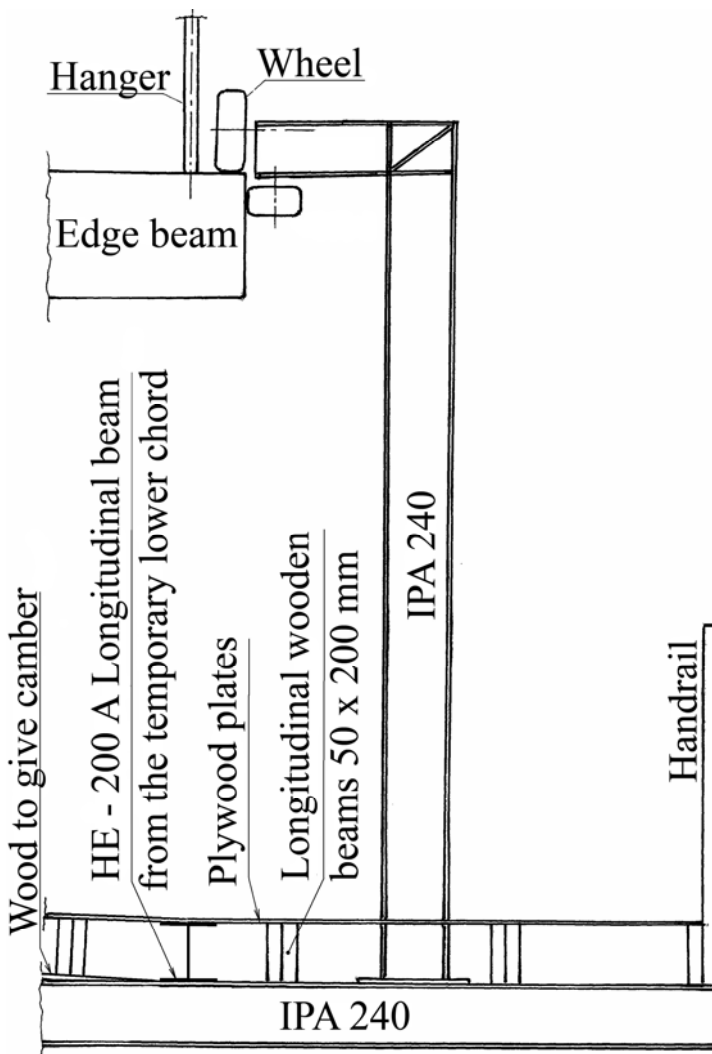

Fig. 31 shows part of a cross-section of a wagon for removing the formwork and the temporary tie of a network arch. p. 52 to 53a. It rolls along the edge of the finished tie.

The floor in the removal wagon has been a part of the formwork for the casting of the tie. It has two extra long transverse beams. It has been lowered after the casting was finished. You can find the longitudinal beam from the temporary lower chord.

Jacks fastened to the lower ends above the lane can move the platform. No personnel are allowed on the platform when it is being moved.

It seems to the author that it is less costly, and/or easier to erect and remove the formwork of a network arch than the formwork in a tie with transverse steel beams.

After the temporary tie and the formwork have been removed, they have a certain value. These materials can also be reused in the temporary tie of another network arch.

Fig. 31. Wagon for removing formwork from a network arch.

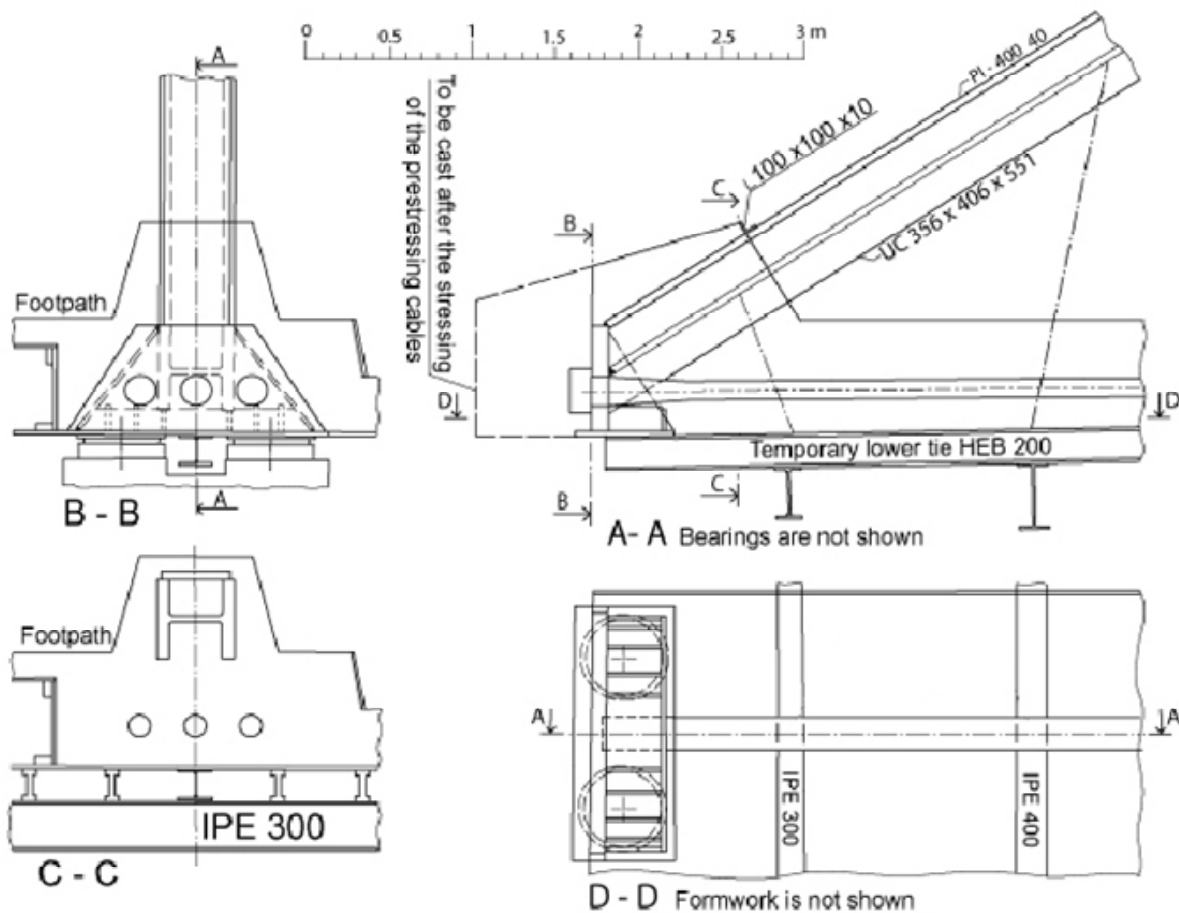

Fig. 32. End of span with temporary tie.

Fig. 32 shows the end of a finished network arch where a temporary lower chord is about to be removed. p. 30. Reinforcement, dowels, and diagonals in the lower chord are not shown. The temporary lower chord ends in a cavity between the bearings. This cavity has room for hydraulic presses if bearings are to be changed.

Fig. 33 shows the lifting of the steel skeleton of the Åkviksund network arch. p. 29. The biggest Norwegian floating crane is being used. It has a capacity of 600 t. The load is 410 t. The steel skeleton weighs 230 t. The remaining 180 t is formwork and reinforcement. How much formwork and reinforcement that is to be lifted must be decided in each case.

Normally one crane at each end of the span will do the lifting. Floating cranes that can lift over 3000 t are available. It seems that finished spans over 300 m can be produced on shore to be lifted onto the site.



Fig. 33. Lifting the steel skeleton of a network arch with a floating crane.

In long narrow bridges vibrations might be a problem. The stiffness and the thin slab tie give the network arch good resistance to vibrations due to wind. Harmful effects of vibrations of the hangers due to wind can be avoided by tying the passing hangers loosely to each other. To avoid damage due to vibrations, the hangers should also be covered by split open plastic tubes where they pass each other. p. 22.

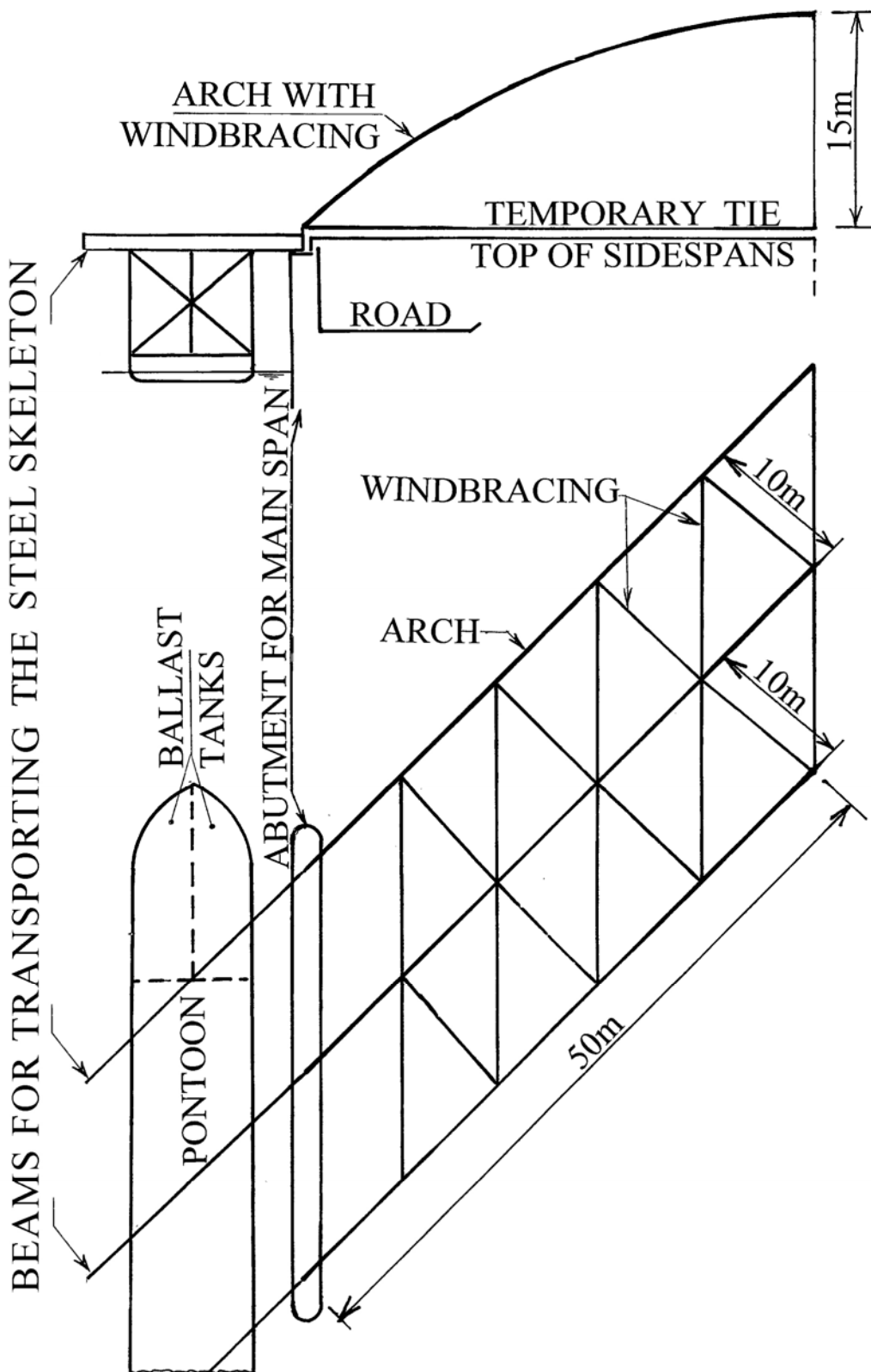

Fig. 34. Erection of a skewed network arch on the edge of a canal.

Fig. 34 shows the first stage of the erection and transport of a skewed bridge across a canal. p. 20. The span is 100 m.

The structural steel, supplemented by a temporary lower chord, is erected at the side-spans at one side of the canal.

If the shape of the steel skeleton is right, then no adjustment of hangers is needed later.

In order to reduce the thickness of the concrete tie, three arches are used.

The structural steel, supplemented by a temporary lower chord, is erected on the ramps or side spans.

While the beams on top of the pontoon are being tied to the abutment, the steel skeleton is rolled to the middle of the pontoon.

Then the pontoon is pulled across the canal. Finally the skeleton is rolled onto the abutments and the concrete tie is cast.

Fig. 35. on the next page shows how a network arch can be erected on the site of the Straubing Bridge. A temporary tie is used. After the arch and hangers have been erected, a pontoon lifts the steel skeleton across the river. Then the steel skeleton is put in place and the tie is cast. [p. 15]

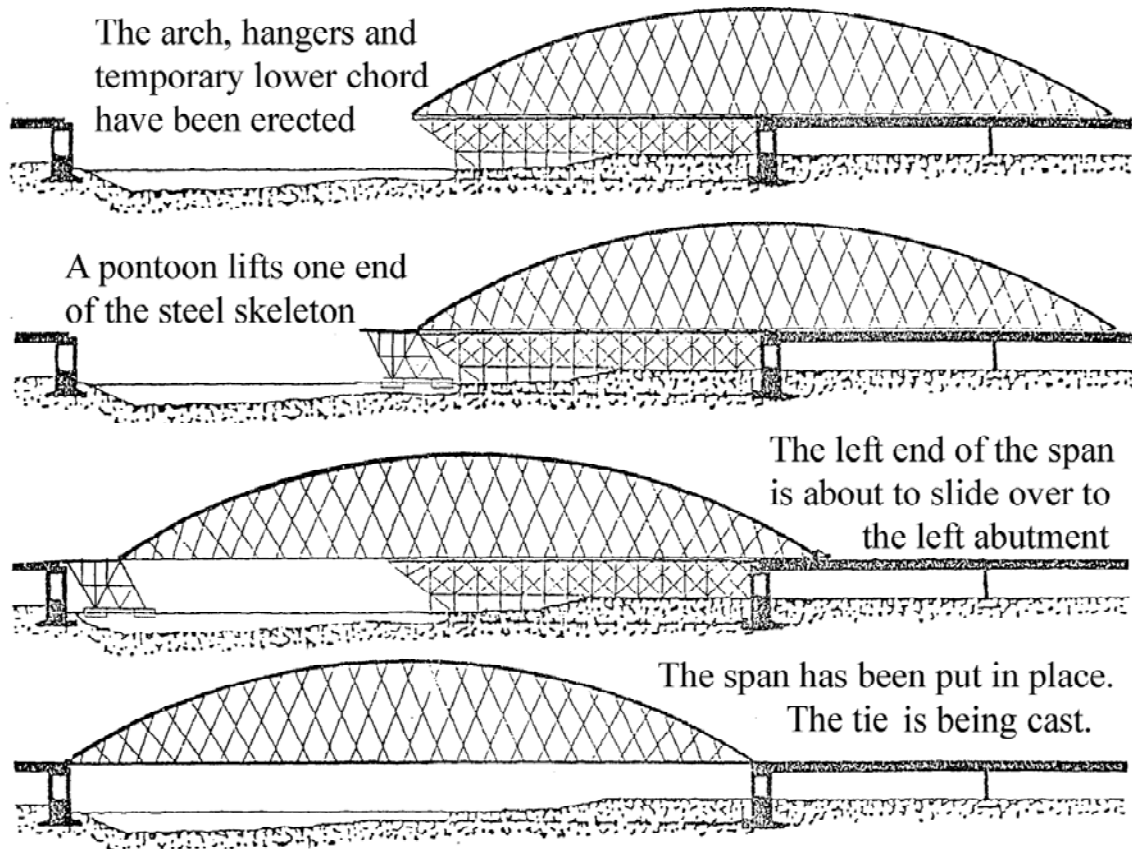

Fig. 35. Erection of a network arch at the site of the Straubing Bridge. See page 9 and 10.

In cold climates network arches can be erected on ice, and lifted onto the pillars. Around 0.7 m thick ice will usually prevent water from seeping onto the ice during the erection. Sufficient thickness of the ice can be achieved by pumping water onto the ice or by spraying drops of water into very cold air above the ice.

Fig 36. shows a double track railway bridge designed by Brunn and Schanack, two German students from Dresden. They did their master's thesis with the author in Norway. Their extensive and valuable calculations can be found on the internet. [Brunn and Schanack 2003]. They are written in English.



Fig. 36. A double track railway bridge designed in 2003.

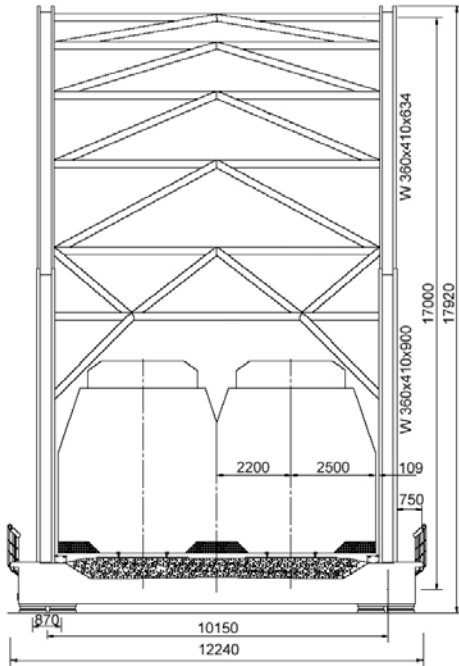
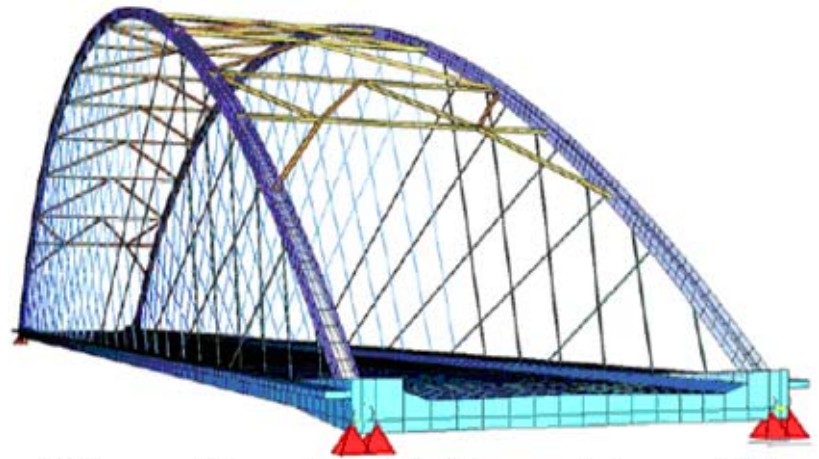

Fig. 37. Another view of the bridge in fig. 35.



View of the 3-D FEM model used for calculations that can be found at <http://fag.grm.hia.no/fagstoff/pert/>

Fig. 38 shows the 3-dimensional finite element model used in the calculations of the bridge in figs 36 and 37.

In fig. 37 the network arch in the previous slide is seen from one end. It has American wide flange beams in the arches and prestressed concrete in the tie. p. 32 and 33.

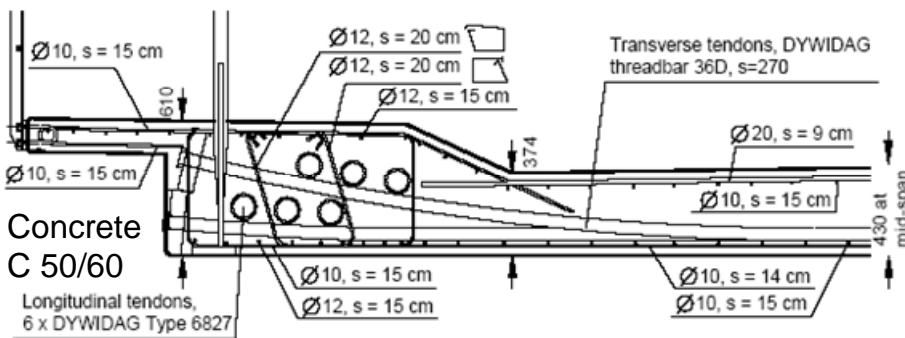

Fig. 39 shows reinforcement in the tie of Brunn and Schanack's railway bridge. Half the anchors of the prestressing rods are passive. The lower ends of the hangers should be tied to anchors of the prestressing rods.

Fig. 39. Reinforcement of the tie in the network arch in fig. 36 to 38.

The curvature of the arch in Brunn and Schanack's bridge is shown in fig. 40. The reduced curvature near the ends of the arches will give shorter wind portals and a more constant force and lower axial force in the arch.

In most of the arch they used a constant angle between arch and hangers. Frank Schanack has done his PhD in Spain this year. [Schanack 2008] He plans a book on network arches. It will be very interesting.

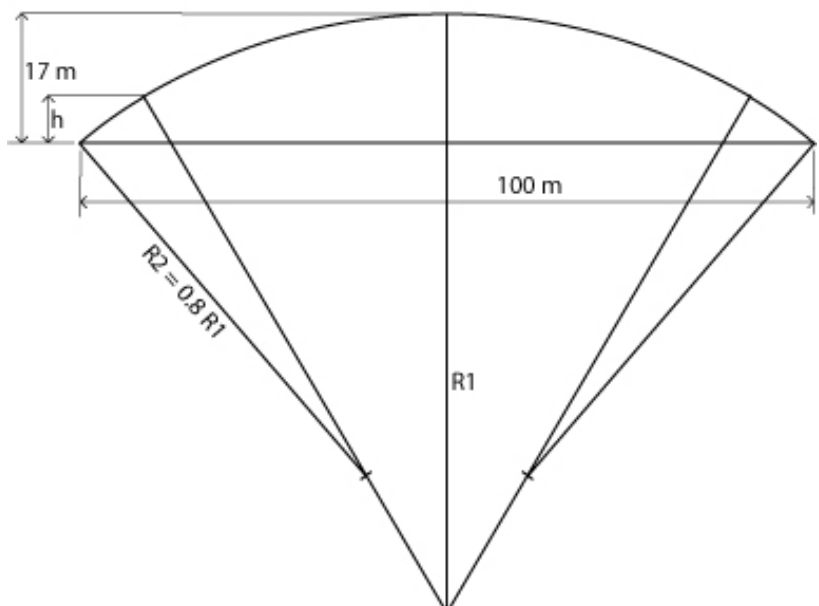
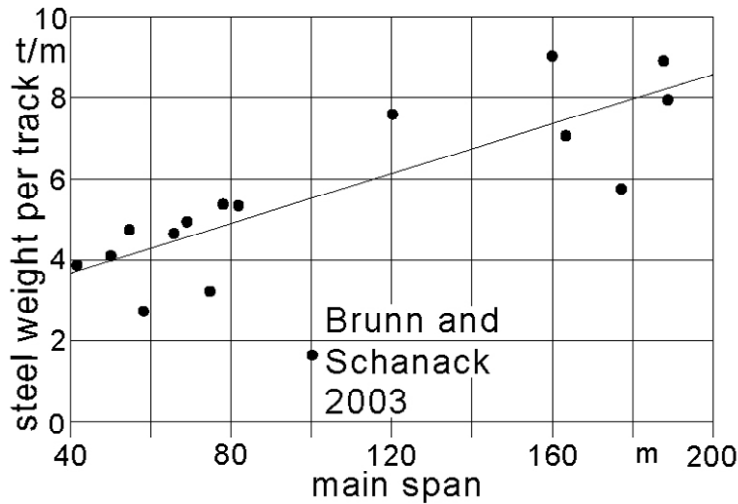

Fig. 40. The curvature of the arch of the bridge in figs. 36 to 38.



Steel weight in railway bridges

Fig. 41. Comparison of steel weights of suggested railway bridge to other railway bridges.

In fig. 41 the steel weight per metre of track of Brunn and Schanack's railway bridge is compared to the steel weight of other railway bridges. [Brunn and Schanack 2003] It can be seen that their bridge uses about a third of the steel needed for other railway bridges.

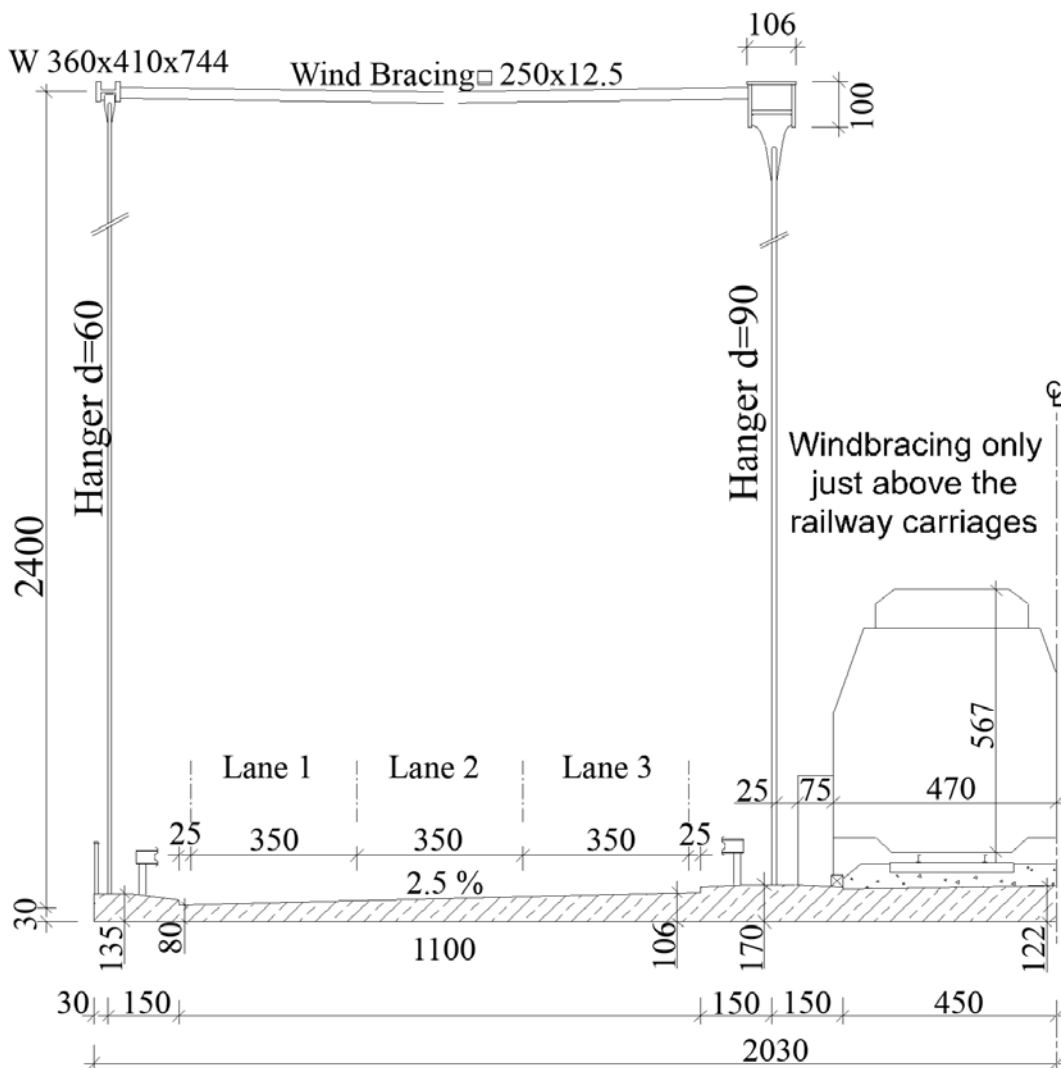

Fig. 42. Network arch bridge for road and rail.

Fig. 42 shows half the cross-section of a bridge designed by Mathias Räck. He was another student from TU-Dresden who did his master's with the author in Norway.

His graduation thesis can be found on the internet. [Rack 2003].

The bridge has three lanes in each direction and two railway tracks in the middle.

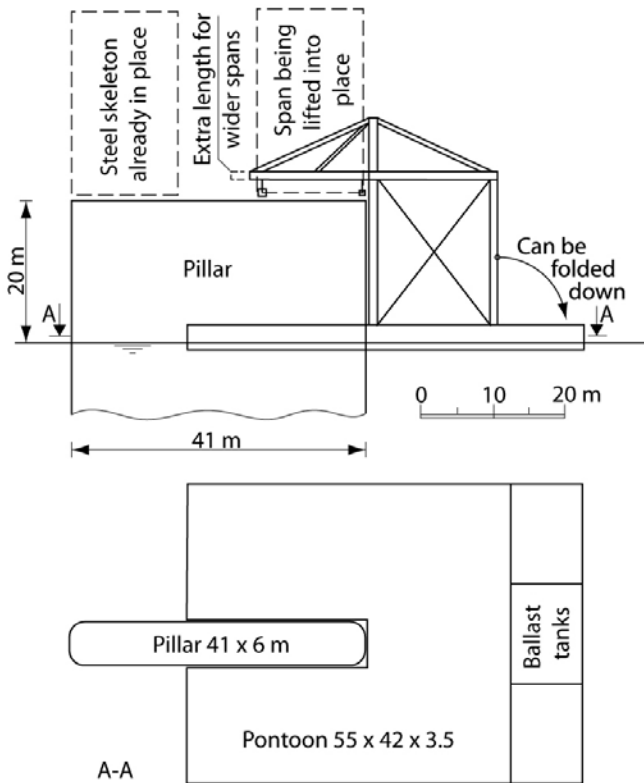

Fig. 43. Crane for lifting the bridge in fig. 40.

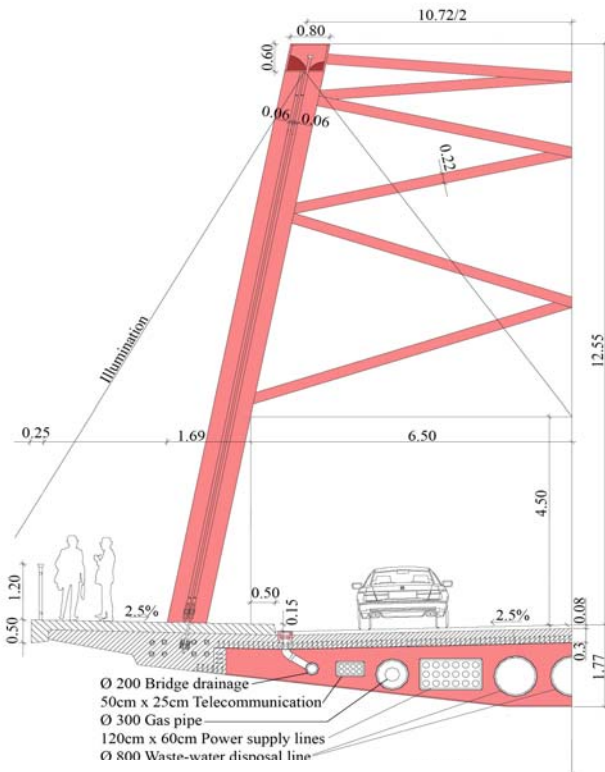

Fig. 44. A suggested network arch.

The crane in fig. 43 can be used to move the 160 m long steel skeleton of Räck's bridge to the pillars. Each of the two steel skeletons weighs ~1000 tonnes.

The crane can be useful in very big rivers. p.54. The crane can be folded down to pass under existing bridges. Each of the steel skeletons weighs ~1000 t.

The boom has extra length so that the crane can be used for wider network arches. When the pillars are higher than 20 m, it might be better to use pontoons and cranes on the pillars for the transport of the steel skeletons.

When both steel skeletons in fig. 43 are in place, they can be joined together and the concrete tie can be cast. At the top of the pillars there must be room for prestressing the longitudinal cables.

The bridge in fig. 44 was suggested for Schulenburg in Berlin. It has a span of 90 m. It was the subject of the master's thesis of Wolfram Beyer in 2006. Frank Schanack was adviser. The slide shows another way of putting the tubes under the tie. This leads to extra height of the tie.

The bridge has transverse steel beams, but the longitudinal beams in the tie are made of concrete. In this way the prestressing cables do not give compression in the steel beams in the tie. Steel and concrete are used most efficiently in all members of this bridge. Mr. Beyer got a prize for outstanding master's thesis at the Technical University in Dresden in Germany.



Fig 45. Picture of the Schulenburg Bridge.

Fig. 45 shows that the Schulenburg Bridge does not look clumsy in spite of the deep beams, but it would have looked even better if the tie had been 0.5 m deep.

The author refers to the works of students, because they try new ideas, and their calculations can be put on the internet. Firms that design network arches have ideas of their own, and have to meet the wishes of bridge authorities. Their calculations are not readily available.

For many years the author published his results hoping that the network arch would become popular. He has been wondering why it took so long. An obvious explanation might be that optimal network arches are not economical. The author is not willing to accept this explanation and will try to come up with other reasons. The network arch is not overly complicated, but all design offices have a shortage of engineers that can be trusted with the design of their first network arch. These engineers have many other tasks that have high priority.

For a firm it might not be economical to find out all about network arches in order to design just one bridge. When a big project comes along, most public bridge offices would like to use well tested ideas tempered by some ideas of their own. Besides they are always short of time. Network arches require co-operation between steel firms and concrete firms. The firms might have less motivation for co-operation because network arches use little steel and little concrete.

Bridge authorities have better reasons for building network arches, but the introduction of the network arch would create extra work for them. If they decide to design their first network arch, they might have fewer man hours to spend on other bridges. If the bridge authorities do not promote network arches, it is hard for others to do so. It is probably mainly conservatism that has held the network arches back. People sometimes come up with non valid reasons against the building of network arches.

The author's ideas have influenced the building of network arches in the Czech Republic, Germany, Norway and the USA. In all these countries it has been decided to build more network arches.

Now let us look at some network arches that have been built or are in the process of being built. Fig. 46 shows a network arch that was built in the Czech Republic in 2004. p. 92a to 92c. It replaces an old bridge with too little room for the 100-year flood.

The existing roads on both sides of the bridge needed only small alterations. The Czech engineer Ladislav Šašek had heard about network arches. He consulted the author's home page and designed this bridge. [Šašek 2005 and 2006]. The author heard about it after it was finished.



Fig. 46. The Bechyne Bridge built in 2004. Span 41 m.

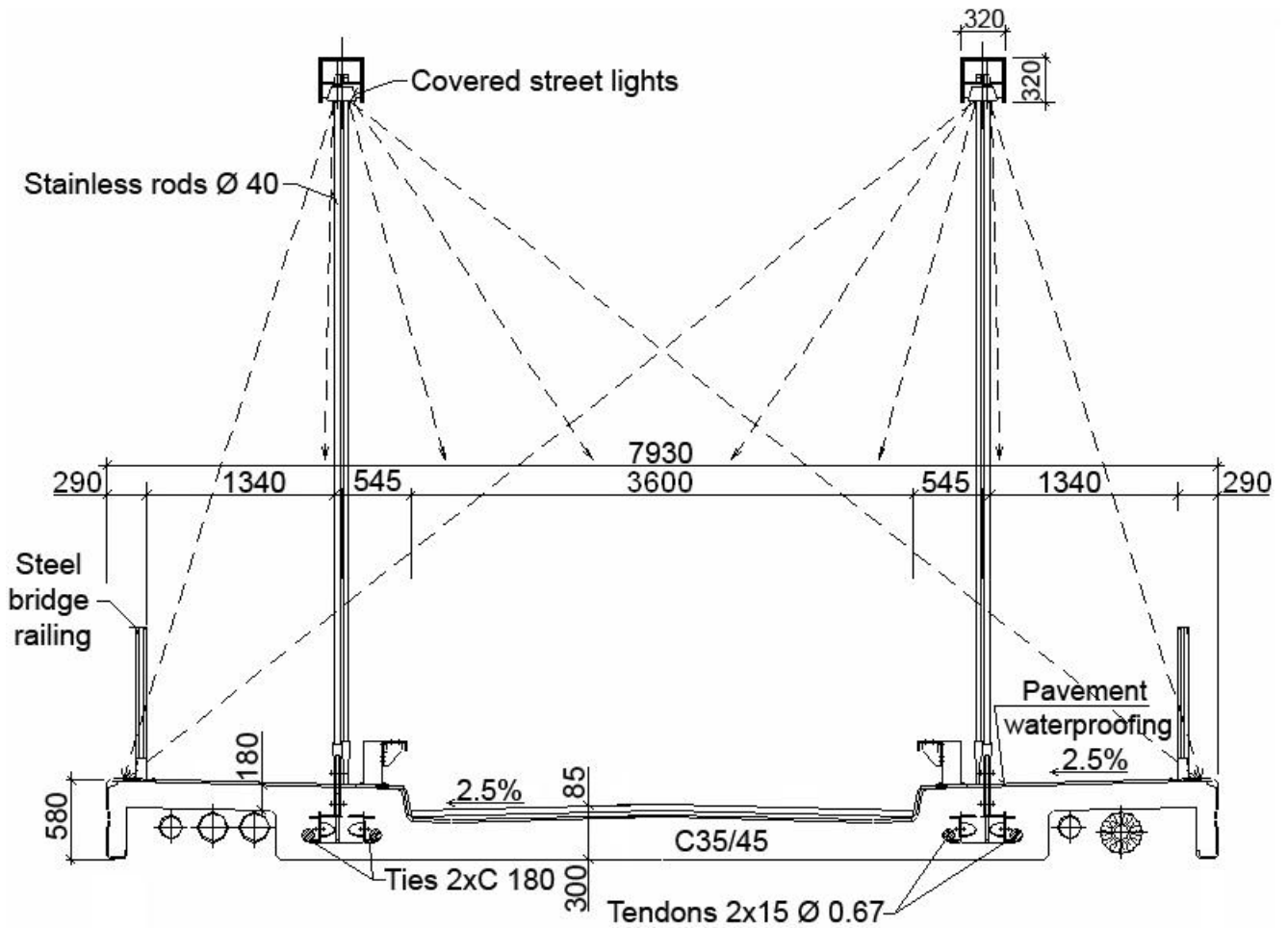

Fig. 47. Cross-section of the Bechyne Bridge.

Fig 47 shows a cross-section of the Bechyne Bridge. Notice how pipes are hidden under the footpath.

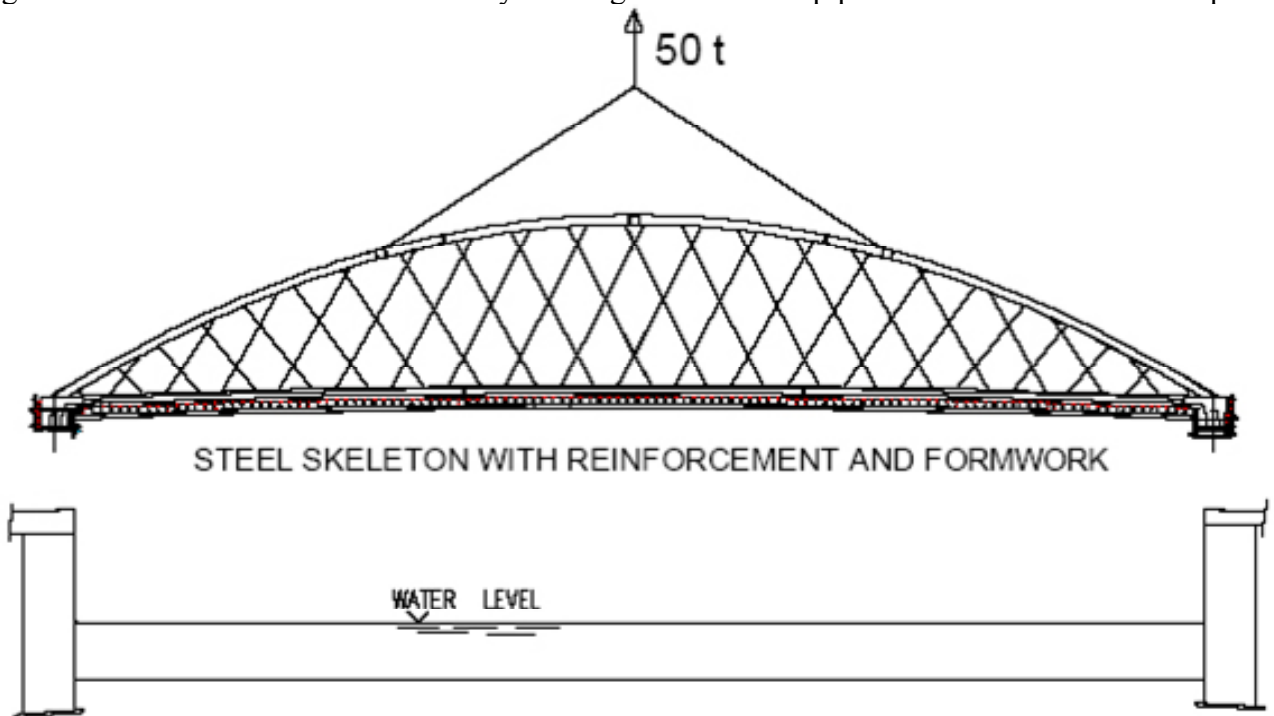

Fig. 48. Erection of the Bechyne Bridge.

Šašek suggested the method of erection shown in fig. 48 for the network arch in Bechyne. The steel skeleton weighs about 30 t. 20 t of the load is formwork and reinforcement.

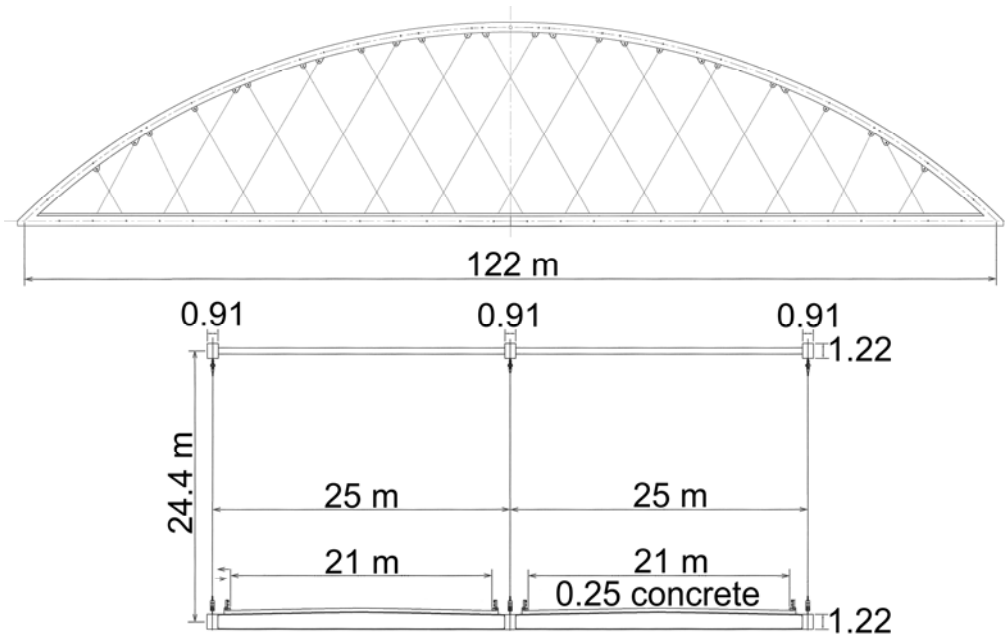

Fig. 49. A network arch in Providence, USA.

The network arch fig. 49 and 50 was opened in 2007. The span is 122 m. It has three arches.



Fig. 50. The steel skeleton of the network arch in Providence ready to be moved.

The Providence network arch was floated 20 km to the site. The History Channel made a program that showed how the 2200 t of steel were moved.

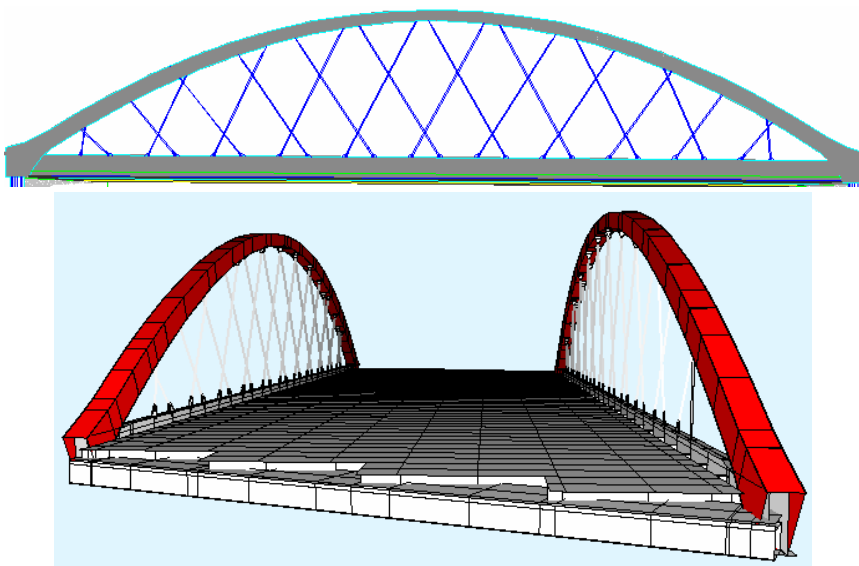

The network arch in fig. 51 was built in 2005 as one of two parallel spans across a motorway in Saxony in Germany. [Graße and Tveit 2007] It has two parallel spans 27.4 m wide, and so there had to be steel beams in the tie. Compared to an alternative with vertical hangers it saved 30% of the steel.

Fig. 51. Network arch built in Saxony in 2005. Span 88 m



Fig. 52. The finished bridge from fig. 51.

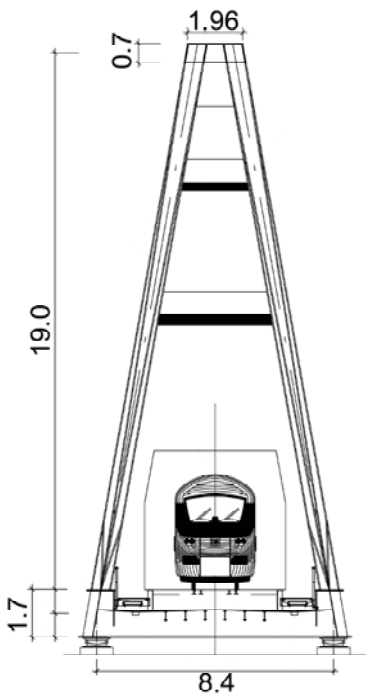

Flora Bridge

This railway bridge is going to be built in Germany. It is so light and stiff that it can be used for train speeds of up to 160 km/h.

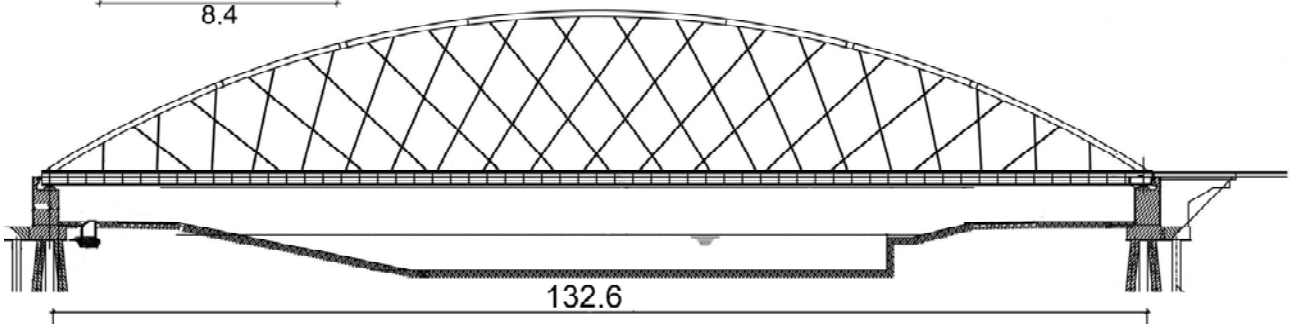

Fig. 53. The Flora bridge.

In fig. 52 the four arches of the two parallel spans seem like three. It is an optical illusion that the tie seems to be sagging. Maybe it should have had a slight upward curvature.

The railway bridge in fig. 53 is going to be built across the Mittelland Canal in Germany. It requires 29 % less steel compared to a similar bridge with vertical hangers. A steel tie has been selected to simplify the erection. If a concrete tie had been used, much more steel could have been saved. The hangers are steel plates. Their welds can take much fatigue. That is important in railway bridges.



Fig. 54. Blennerhassett Bridge over the Ohio River in the USA. Span 268 m

The main span in Fig. 54 was erected from pillars in the river. The distance between the pillars allows ships to pass. [Wollmann and Zoli 2008] say that “compared to a bridge with vertical hangers the crossing hangers reduce the live load deflections by a factor of 11. Arch rib and tie beam bending moments are reduced by a factor of 4 and 5 respectively. There is 32.6 m between the planes of the arches. With the great width of the bridge and the correspondingly heavy concrete deck slab, live load stresses in the inclined hangers remain low and hanger unloading is not an issue.”

The railway bridge in fig. 55 was suggested by Professor Steffen Marx in Dresden. p. 37. It has a concrete tie. The upper parts of the concrete tie can be changed. Note how the hangers are fastened to the vertical plates in the arch.

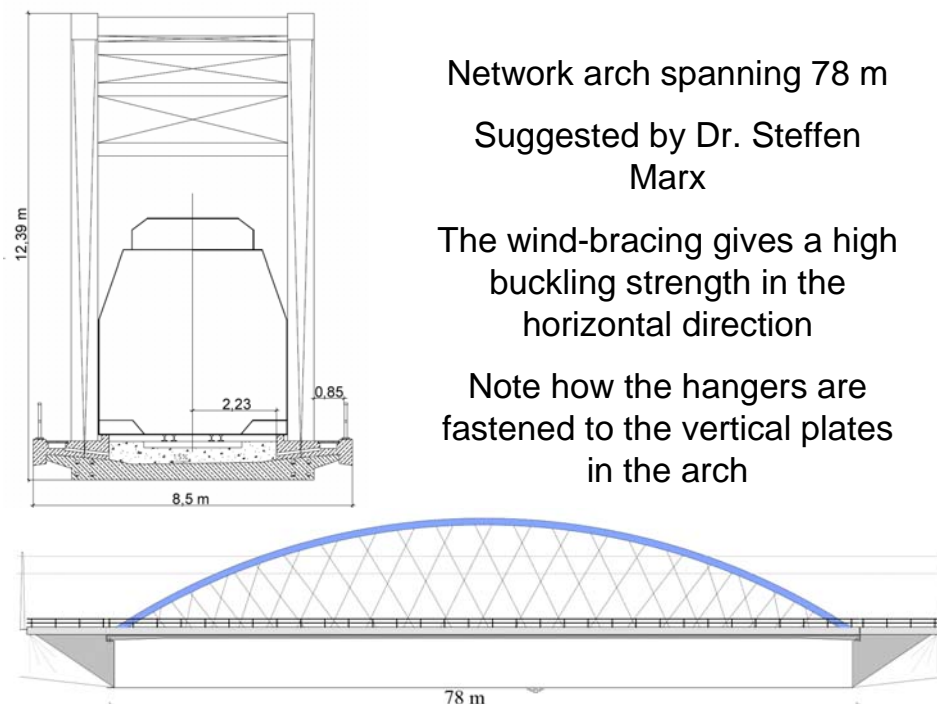

Network arch spanning 78 m

Suggested by Dr. Steffen Marx

The wind-bracing gives a high buckling strength in the horizontal direction

Note how the hangers are fastened to the vertical plates in the arch

Network arches with concrete ties are lighter and stiffer than other steel bridges using the same amount of steel.

Resistance to earthquakes will be good. This is due to the high strength to weight ratio and much reinforcement in the edge beams. It is important that bridges are intact after an earthquake. Then help can be brought in fast.

Fig. 55. Railway bridge with a concrete tie.



Fig. 56. The Svinesund Bridge between Norway and Sweden.

The arch bridge in fig. 56 was opened in 2005 to commemorate the peaceful dissolution of the union between Sweden and Norway in 1905. The main span is 247 m. [Steiner and Wagner 2005] The two steel boxes are the same for the 4 km length of the bridge.

A group of the author's students designed an alternative further out in the fjord. See fig. 59. They assumed concrete in the side-spans. They needed about 4000 tonnes less steel. For the two network arches of the main span the students needed 450 t of steel. Otherwise the quantities were not very different. The bridge that was built needed 970 t of steel and 5300 m³ of concrete. The students found that they needed 1200 t and 5500 m³. The students' quantities are preliminary.

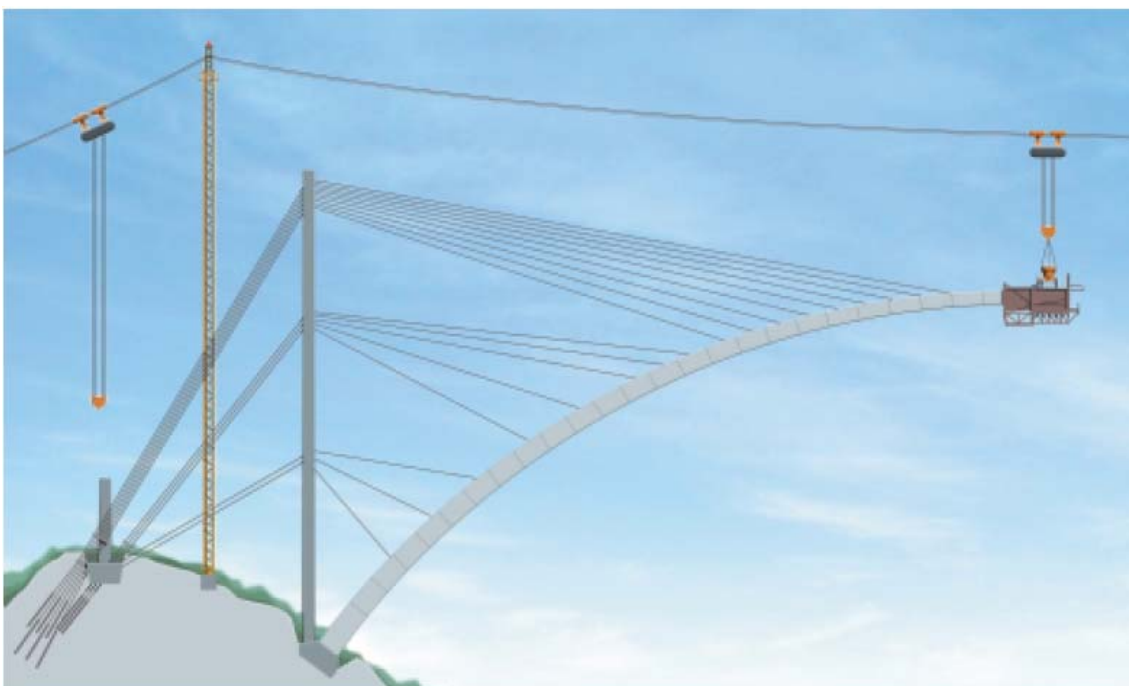

Fig. 57 shows the extensive arrangement for casting the arch of the Svinesund Bridge. It is a fairly standard method for erecting concrete arches.

Fig. 57. Erection of the arch of the Svinesund Bridge.



Fig. 58 Closing the Svinesund Bridge.

Fig. 58 shows the lifting of the middle of the tie of the main span. The weight to be lifted was 1450 t. It was not simple. Steel sections were produced in Germany. They were transported on a pontoon to a harbour built in Svinesund. There they were assembled to be transported to the site.



Fig. 59. The students' Svinesund Bridge.

The students' two parallel spans for the Svinesund Bridge are 135 m long. They could have been completely finished on a quay 20 km from the site. Two big floating cranes that could lift at least 800 t each could transport the main spans to the site.

My wife prefers the present bridge. Furthermore it seems right to commemorate the peaceful dissolution of the union between two countries by building a beautiful bridge between them.

In real life the students' bridge would have looked better than in the picture. The hangers would hardly have been seen. The combined height of the four arches would have been about half of the height of the arch in the bridge that was built. The tie in the bridge that was built is about 7 times as deep as the tie in the students' spans.

The Svinesund Bridge is mentioned to illustrate another point. Like in the Svinesund Bridge, big roads often have two lanes plus a stopping lane in each direction. The two directions can be built meters apart. If network arches were used, two parallel spans would be lighter than one and easier to erect.

If universal columns were used, the very slender arches would look good from a distance. Sometimes the same temporary lower chord could be used for both spans.

In many places heavier traffic can be expected in the future. Then it might be economical to build one span sufficient for carrying the present traffic. Two parallel spans should be planned, and the second span should be added when the first span becomes congested.

It seems to the author that the network arch with a concrete tie might be the optimal solution for bridge spans between 40 m and up to and over 300 m. Maybe it competes best for spans between 80 and 150 m, but the site is more important than the span.

SUMMING UP Network arches are equally well suited for road and rail bridges. They use very little steel. An optimal network arch is likely to remain the world's most slender tied arch bridge. The slim chords are pleasing to the eye and do not hide the landscape or cityscape behind them.

If the bridge is not too wide, the tie should be a concrete slab. Concrete ties with small edge beams can be used for up to and over 15 m between the arches. Efficient methods of erection are available. Since the network arch needs little materials, a high percentage of the cost will be employment. The poverty in some parts of the world is one more reason for using the network arch at suitable sites.

Depending on the site, the network arch can save up to 40% of the cost and 70 % of the steel. If the network arch had been a well known type of bridge, it would sometimes have been hard to argue convincingly for arch bridges with vertical hangers and many other bridge types.

Conservatism is the main obstacle to the building of network arches.

Literature

- Brunn, B. and Schanack, F. (2003) "Calculation of a double track railway network arch bridge applying the European standards" Graduation thesis at TU-Dresden. August 2003. 320 pages. A revised version of this thesis can be found at <http://fag.grm.hia.no/fagstoff/ptveit/>
- Graße, W. and Tveit, P. (2007) "Netzwerkbogenbrücken – Geschichte, Tragverhalten und ausgeführte Beispiele" (Network Arches – History, Function and Built Examples. In German.) 17. Dresdner Brückenbausymposium. 13. March 2007. ISSN 1613-1169, ISBN 3-86005-542-9
- Geißler, K., Steimann, U. and Graße, W. "Netzwerkbogenbrücken - Entwurf, bemessung, Ausführung" (Network Arch Bridges - Design and Execution. In German.) Der Stahlbau, H. 3, 2008, Berlin, pp. 158-171.
- Herzog, Max. (1975). "Stahlgewichte moderner Eisenbahn- und Straßenbrücken." (Steel Weights of Modern Rail- and Road-bridges.) Der Stahlbau 9/1975
- Larsen, R. L. and Aas-Jakobsen, K. (2006). "Brandangersundet Bru – Verdens slankeste?" "Brandangersundet Bridge – The World's Most Slender?" (In Norwegian). Stålbyggnad, Stockholm, 2006. No. 2. p. 37-38. ISSN 1404-9414

- Naruoka, M., Itoh, K., Matsukawa, A. (1977) "Nielsen System Bridges in Japan" Pflüger Festschrift, Hannover, pp.193 to 203
- Nielsen, O. F. (1930) "Foranderlige Systemer med anvendelse på buer med skraatstillede Hængestenger." ("Discontinuous systems used on arches with inclined hangers", in Danish.) 121 pages. Gad, Copenhagen. Ph.D. thesis.
- Nielsen, O.F. (1932) "Bogenträger mit Schräg gestellten Hängestangen." ("Arches with inclined hangers," in German.) Internationale Vereinigung f. Brückenbau und Hochbau. Abhandlungen 1, 1932. pp. 355-363.
- Ostenfeld, C. (1976) "Christiani & Nielsen, Jernbetonens danske pionerer" ("Christiani & Nielsen, The Danish Pioneers of Reinforced Concrete," In Danish.) Polyteknisk Forlag, Lyngby, Denmark.
- Räck, M. (2003) "Entwurf einer kombinierten Straßen-Eisenbahn-Netzwerkbogen-brücke" (Draft of a Network Arch for a Combined Road and Railway Bridge) Graduation thesis at TU-Dresden. August 2003. 237 pages. A revised version of this thesis can be found at <http://fag.grm.hia.no/fagstoff/ptveit/>
- Šašek. L. (2005). "Getting on the Network. Innovation in arch design" BRIDGE Design & Engineering. v. 11, no 40, pp. 39-40.
- Šašek. L. (2006). "Less is More", Civil Engineering, The magazine of the American society of civil engineers - ASCE, April 2006, pp. 50-55.
- Schanack, F., (2008) "Puentes en Arco Tipo Network, Network arch bridges", Ph.D. thesis at Departamento de Ingenieria Estructural y Mecanica, E. T. S. de Ingenieria de Cantabria. Santander, Spania, 2008
- Stein, Peter and Wild, H. (1965). "Das Bogentragwerk der Fehmarnsundbrücke." ("The arch of the Fehmarnsund Bridge" In German.).
- Steiner, G. and Wagner, P. (2005) "Die Svinesundbrücke. Besonderheiten bei Entwurf, Fertigung und Montage der Stahlkonstruktion" ("The Svinesund Bridge. Particularities of design, fabrication and erection of the steel superstructure").Stahlbau 2005 Heft 2. pp. 73-86.
- Strobel, W., Kovacs, I., Andra, H.and Häberle, U. (2007) "Eine Fußgängerbrücke mit einer Spannweite von 230m." ("A pedestrian bridge with a span of 230m.") Der Stahlbau 2007, Heft 12, pp. 869-876.
- Teich, S. and Wendelin, S. (2001) „Vergleichsrechnung einer Netzwerkbogenbrücke unter Einsatz des Europäischen Normenkonzepts.“ (In German). Graduation thesis at TU-Dresden. August 2001. 300 pages. A revised version of this thesis can be found at <http://fag.grm.hia.no/fagstoff/ptveit/>
- Tveit, P. (1955) Graduation thesis on arch bridges with inclined hangers. Delivered in September 1955. 76 pages. At the Technical University of Norway, Trondheim.
- Tveit, P. (1959) "Bogebruer med skrå krysstilte hengestenger." ("Arch bridges with inclined intersecting hangers," in Norwegian.) Ph.D. thesis presented at the Tech. Univ. of Norway. 64 pages, 78 drawings.
- Tveit, P. (1964) "Nettverkbogar, ein ny brutype". ("Network Arches, a New Type of Bridge." In Norwegian.) Bygg, Vol. 12, May 1964, pp.105-113.
- Tveit, P. (1966) "Design of Network Arches." Struct. Eng., 44(7). London, England, pp. 247-259.
- Tveit, P. (1980) "Network Arches." 11th IABSE Congress, held in Vienna, Austria, *Final Report*, IABSE, ETH-Hönggerberg, CH-8039, Zürich, Switzerland, pp. 817-818.
- Tveit, P. (2006). "Nettverkbrogar, en effektiv kombinasjon av stål og betong" "Network arches, an efficient combination of steel and concrete." (In Norwegian). Stålbyggnad, Stockholm, 2006. No. 2. pp. 33-35. ISSN 1404-9414
- Tveit, P. (2007) "The Network Arch. Bits of Manuscript after Lectures in 44 Countries" 140 pages. <http://pchome.grm.hia.no/~pchome/> This home page will be updated at irregular intervals. Consequently some of the page numbers given in this edition might become slightly wrong in the future.
- Wollman, G. and Zoli, T. (2008) "Bridge across Ohio River and Blennerhassett Island" Structural Engineering International 1/2008, Volume 18, Number 1, February 2008. pp. 28 – 30.
- Zoli, T. and Woodward, R. (2005) "Design of Long Span Bridges for Cable Loss." IABSE Symposium, Structures and Extreme Events, September pp. 14-17, Lisbon, Portugal.